



STP1612PW05

16-channel LED driver with 16-bit PWM,
8-bit gain and full LED error detection

Preliminary data

Features

- 16 constant current output channels
- Supply voltage: 3.3 V or 5 V
- Two PWM selectable counters 12/16-bit of grayscale
- Selectable enhanced PWM for ghost effect reduction
- Open and short LED detection
- 8-bit current gain control by means of 256 steps in two selectable ranges
- Single resistor to set the current from 3 mA to 60 mA
- Programmable progressive output delay
- Thermal protection and thermal flag
- UVLO
- Schmitt trigger input
- Selectable 16-bit or 256-bit serial data-in format
- Max clock frequency: 30 MHz
- ESD protection 2.5 kV HBM, 200 V MM
- Drop-in compatible with STP16CP\S\SDP05 series
- Available in high thermal efficiency TSSOP exposed pad

Applications

- Video display LED panels
- RGB backlighting
- Special lighting

Table 1. Device summary

| Order code | Package | Packaging |
|-----------------|---------------------|---------------------|
| STP1612PW05QTR | QFN-24 | 4000 parts per reel |
| STP1612PW05MTR | SO-24 | 1000 parts per reel |
| STP1612PW05TTR | TSSOP24 | 2500 parts per reel |
| STP1612PW05XTTR | TSSOP24 exposed pad | 2500 parts per reel |

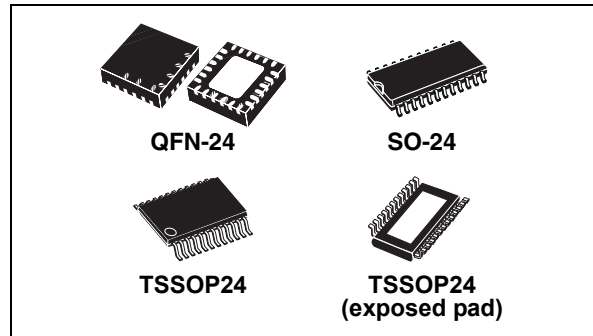

Description

The STP1612PW05 is a 16-channel constant current sink LED driver. The maximum output current value for all the 16 channels is set by a single resistor from 3 mA to 60 mA. The device features 8-bit gain (256 steps) for global LED brightness adjustment with two selectable ranges. This function is accessible via a serial interface. The device has an individual adjustable PWM brightness control for each output channel. The PWM counters are selectable via a serial interface with 4096 or 65536 steps (12 or 16 bit). The STP1612PW05 also provides enhanced pulse-width modulation counting algorithms called e-PWM to reduce flickering effects (ghost visual effects) improving the overall image quality. The device has a dual size 16-bit or 256-bit shift register. All the control and the shift register read back data are accessible via serial interface. The STP1612PW05 has the capability to detect open and short LED failure and overtemperature, reporting the status through SPI line. The device guarantees a 20 V output driving capability, allowing the user to connect more LEDs in series.

Contents

| | | |
|-----------|---|-----------|
| 1 | Block diagram | 4 |
| 2 | Summary description | 5 |
| | 2.1 Pin connection and description | 6 |
| 3 | Electrical ratings | 7 |
| | 3.1 Absolute maximum ratings | 7 |
| | 3.2 Thermal data | 7 |
| | 3.3 Recommended operating conditions | 8 |
| 4 | Electrical characteristics | 9 |
| 5 | Timing waveform | 13 |
| 6 | Principle of operation | 14 |
| 7 | Definition of configuration register | 16 |
| 8 | Grey scales data loading | 17 |
| 9 | Setting the PWM gray scale counter | 18 |
| | 9.1 PWM data synchronization | 18 |
| | 9.2 Synchronization for PWM counting | 19 |
| 10 | Error detection conditions | 20 |
| 11 | Setting output current | 21 |
| 12 | Current gain adjustment | 22 |
| 13 | Delay time of staggered output | 23 |
| 14 | Thermal protection | 23 |
| 15 | Time-out alert of GCLK disconnection | 24 |

16 **Package mechanical data** **25**

17 **Revision history** **32**

1 Block diagram

Figure 1. Block diagram

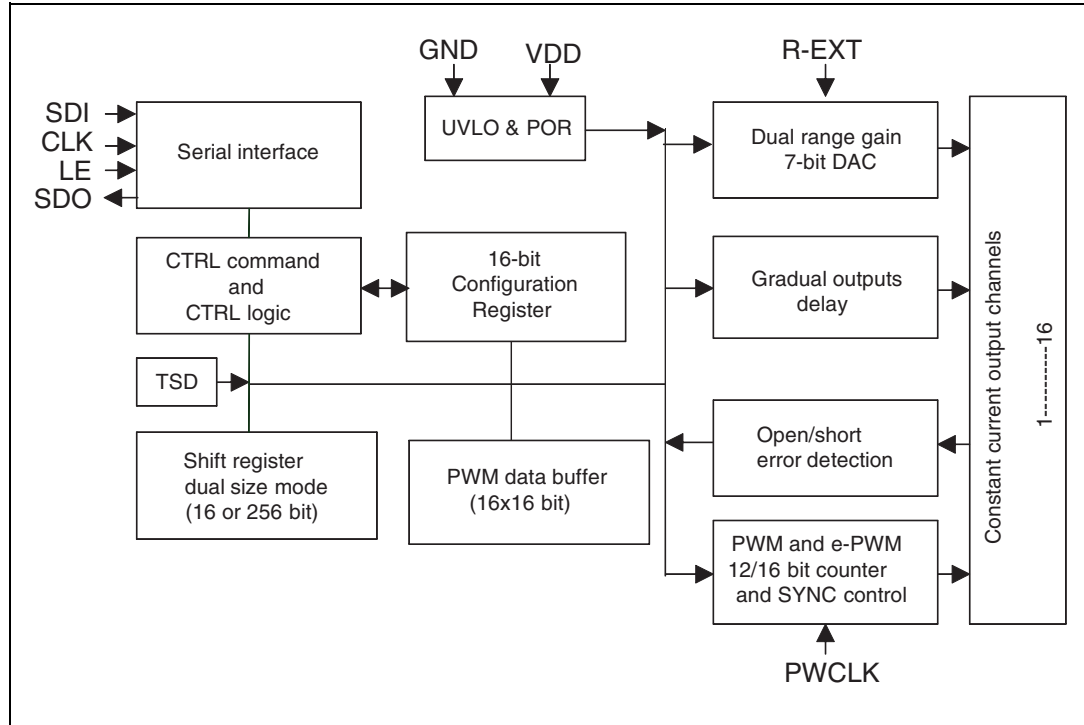

2 Summary description

Table 2. Typical current accuracy at 5 V

| Output voltage | Current accuracy | | Output current | V _{DD} | temp. |
|----------------|------------------|-------------|----------------|-----------------|-------|
| | Between bits | Between ICs | | | |
| ≥ 1.0 | ± 1.5% | ± 6% | 15 to 60 | 5 V | 25 °C |
| ≥ 0,2 | ± 1.5% | ± 6% | 3 to 15 | | |

Table 3. Typical current accuracy at 3.3 V

| Output voltage | Current accuracy | | Output current | V _{DD} | temp. |
|----------------|------------------|-------------|----------------|-----------------|-------|
| | Between bits | Between ICs | | | |
| ≥ 1.0 | ± 1.5% | ± 6% | 15 to 60 | 3.3 V | 25 °C |
| ≥ 0,3 | ± 1.5% | ± 6% | 3 to 15 | | |

2.1 Pin connection and description

Figure 2. Pin connection

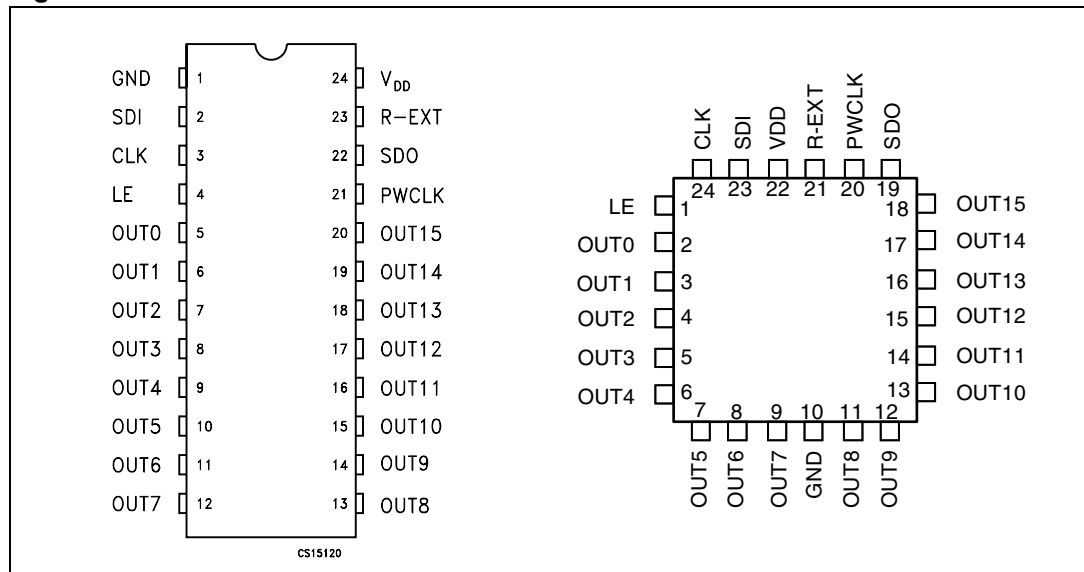

Note: The exposed pad should be electrically connected to a metal land electrically isolated or connected to ground

Table 4. Pin description

| Pin n° | Symbol | Name and function |
|--------|-----------------|---|
| 1 | GND | Ground terminal |
| 2 | SDI | Serial data input terminal |
| 3 | CLK | Clock input terminal used to shift data on rising edge and carries command information when LE is asserted. |
| 4 | LE | Data strobe terminal and controlling command with CLK |
| 5-20 | OUT 0-15 | Output terminals |
| 21 | PWCLK | Gray scale clock terminal. Reference clock for grey scale PWM counter. |
| 22 | SDO | Serial data out terminal |
| 23 | R-EXT | Input terminal of an external resistor for constant current programming |
| 24 | V _{DD} | Supply voltage terminal |

3 Electrical ratings

3.1 Absolute maximum ratings

Stressing the device above the rating listed in the [Table 5](#) may cause permanent damage to the device. These are stress ratings only and operation of the device at these or any other conditions above those indicated in the operating sections of this specification is not implied. Exposure to absolute maximum rating conditions for extended periods may affect device reliability.

Table 5. Absolute maximum ratings

| Symbol | Parameter | Value | Unit |
|-----------|---|------------------|------|
| V_{DD} | Supply voltage | 0 to 7 | V |
| V_O | Output voltage | -0.5 to 20 | V |
| I_O | Output current | 60 | mA |
| V_I | Input voltage | -0.4 to V_{DD} | V |
| I_{GND} | GND terminal current | 1300 | mA |
| f_{CLK} | Clock frequency | 50 | MHz |
| T_J | Junction temperature range ⁽¹⁾ | -40 to +170 | °C |

1. Such absolute value is based on the thermal shutdown protection.

3.2 Thermal data

Table 6. Thermal data

| Symbol | Parameter | Value | Unit | |
|-------------|--|---------------------------------------|------|------|
| T_A | Operating free-air temperature range | -40 to +125 | °C | |
| T_{J-OPR} | Operating thermal junction temperature range | -40 to +150 | °C | |
| T_{STG} | Storage temperature range | -55 to +150 | °C | |
| R_{thJA} | Thermal resistance junction-ambient ⁽¹⁾ | SO-24 | 42.7 | °C/W |
| | | TSSOP24 | 55 | °C/W |
| | | TSSOP24 ⁽²⁾ Exposed pad | 37.5 | °C/W |
| | | QSOP-24 | 55 | °C/W |

1. According to Jedec standard 51-7B

2. The exposed pad should be soldered directly to the PCB to realize the thermal benefits.

3.3 Recommended operating conditions

Table 7. Recommended operating conditions at 25 °C, $V_{DD} = 5\text{ V}$

| Symbol | Parameter | Test conditions | Min. | Typ. | Max. | Unit |
|----------------|----------------------|---|--------------|------|--------------|------|
| V_{DD} | Supply voltage | | 3.0 | - | 5.5 | V |
| V_O | Output voltage | | | - | 20 | V |
| I_O | Output current | OUTn | 3 | - | 60 | mA |
| I_{OH} | Output current | SERIAL-OUT | | - | +1 | mA |
| I_{OL} | Output current | SERIAL-OUT | | - | -1 | mA |
| V_{IH} | Input voltage | | $0.7 V_{DD}$ | - | V_{DD} | V |
| V_{IL} | Input voltage | | GND | - | $0.3 V_{DD}$ | V |
| t_{wLAT} | LE pulse width | $V_{DD} = 3.3\text{ V to }5.0\text{ V}$ | 20 | - | | ns |
| t_{wCLK} | CLK pulse width | | 10 | - | | ns |
| t_{wEN} | PWCLK pulse width | | 20 | - | | ns |
| $t_{SETUP(D)}$ | Setup time for DATA | | 5 | - | | ns |
| $t_{HOLD(D)}$ | Hold time for DATA | | 5 | - | | ns |
| $t_{SETUP(L)}$ | Setup time for LATCH | | 5 | - | | ns |
| f_{CLK} | Clock frequency | Cascade operation ⁽¹⁾ | | - | 30 | MHz |

1. If the device is connected in cascade, it may not be possible to achieve the maximum data transfer. Please consider the timings carefully.

4 Electrical characteristics

$T_A = 25\text{ °C}$ (Unless otherwise specified)

Table 8. Electrical characteristics ($V_{DD} = 5.0\text{ V}$)

| Symbol | Characteristics | Test conditions | Min. | Typ. | Max. | Unit |
|-----------------|--|---|----------------|-----------|----------------|------------------|
| V_{DD} | Supply voltage | | 4.5 | 5.0 | 5.5 | V |
| V_O | Maximum output voltage | $\overline{OUT0} \sim \overline{OUT15}$ | | | 20 | V |
| I_{OUT} | Output current | $V_O = 1.2\text{ V}$ | 5 | | 60 | mA |
| I_{OH} | | SDO, $T_A = -40 \sim 125\text{ °C}$ | | | -8 | mA |
| I_{OL} | | SDO, $T_A = -40 \sim 125\text{ °C}$ | | | 8 | mA |
| V_{IH} | Input voltage "H" level | $T_A = -40 \sim 125\text{ °C}$ | 0.7 * V_{DD} | | V_{DD} | V |
| V_{IL} | Input voltage "L" level | $T_A = -40 \sim 125\text{ °C}$ | GND | | 0.3 * V_{DD} | V |
| I_{OH} | Output leakage current | $V_O = 20\text{ V}$ | | | 10 | μA |
| V_{OL} | Output voltage SDO | $I_{OL} = +1.0\text{ mA}$, $T_A = -40 \sim 125\text{ °C}$ | | | 0.4 | V |
| V_{OH} | | $I_{OH} = -1.0\text{ mA}$, $T_A = -40 \sim 125\text{ °C}$ | $V_{DD} - 0.4$ | | | V |
| dI_{OUT1} | Current skew (Channel) | $I_{OUT} = 10\text{ mA}$ $V_O = 1.0\text{ V}$, $R_{ext} = 69\text{ k}\Omega$ | | ± 1.5 | ± 3.0 | % |
| dI_{OUT2} | Current skew (IC) | $I_{OUT} = 10\text{ mA}$ $V_O = 1.0\text{ V}$, $R_{ext} = 69\text{ k}\Omega$ | | ± 3.0 | ± 6.0 | % |
| $\%/dV_O$ | Output current vs. output voltage regulation | V_O within 1.0 V and 3.0 V, $R_{ext} = 34.7\text{ k}\Omega$ @ 20 mA | | ± 0.1 | ± 0.5 | % / V |
| $\%/dV_{DD}$ | Output current vs. supply voltage regulation | V_{DD} within 4.5 V and 5.5 V | | ± 1.0 | ± 5.0 | % / V |
| $V_{O,TH}$ | | | | 0.15 | 0.20 | V |
| $R_{IN(down)}$ | Pull-down resistor | LE | 150 | 200 | 250 | $\text{k}\Omega$ |
| $I_{DD(off) 1}$ | Supply current "Off" | $R_{ext} = \text{Open}$, $\overline{OUT0} \sim \overline{OUT15} = \text{Off}$ | 7 | 10 | 13 | mA |
| $I_{DD(off) 2}$ | | $I_O = 20\text{ mA}$, $\overline{OUT0} \sim \overline{OUT15} = \text{Off}$ | 6.6 | 9.5 | 12 | |
| $I_{DD(off) 3}$ | | $I_O = 60\text{ mA}$, $\overline{OUT0} \sim \overline{OUT15} = \text{Off}$ | 9 | 12.7 | 16.5 | |
| $I_{DD(on) 1}$ | Supply current "On" | $I_O = 20\text{ mA}$, $\overline{OUT0} \sim \overline{OUT15} = \text{On}$ | 6.6 | 9.4 | 12.2 | |
| $I_{DD(on) 2}$ | | $I_O = 60\text{ mA}$, $\overline{OUT0} \sim \overline{OUT15} = \text{On}$ | 8 | 11.5 | 14.9 | |

Table 9. Electrical characteristics ($V_{DD} = 3.3\text{ V}$)

| Symbol | Characteristics | Test conditions | Min. | Typ. | Max. | Unit |
|----------------|--|--|----------------|-----------|----------------|------------------|
| V_{DD} | Supply voltage | | 3.0 | 3.3 | 3.6 | V |
| V_O | Sustaining voltage at OUT Ports | $\overline{OUT0} \sim \overline{OUT15}$ | | | 20 | V |
| I_{OUT} | Output current | $V_O = 1.2\text{ V}$ | 5 | | 60 | mA |
| I_{OH} | | SDO, $T_A = -40 \sim 125\text{ }^\circ\text{C}$ | | | -1.0 | mA |
| I_{OL} | | SDO $T_A = -40 \sim 125\text{ }^\circ\text{C}$ | | | 1.0 | mA |
| V_{IH} | Input voltage "H" level | $T_A = -40 \sim 125\text{ }^\circ\text{C}$ | $0.7 * V_{DD}$ | | V_{DD} | V |
| V_{IL} | Input voltage "L" level | $T_A = -40 \sim 125\text{ }^\circ\text{C}$ | GND | | $0.3 * V_{DD}$ | V |
| I_{OH} | Output leakage current | $V_O = 17.0\text{ V}$ | | | 0.5 | μA |
| V_{OL} | Output voltage SDO | $I_{OL} = +1.0\text{ mA}$, $T_A = -40 \sim 125\text{ }^\circ\text{C}$ | | | 0.4 | V |
| V_{OH} | | $I_{OH} = -1.0\text{ mA}$ $T_A = -40 \sim 125\text{ }^\circ\text{C}$ | 2.9 | | | V |
| dI_{OUT1} | Current skew (channel) | $I_{OUT} = 10.5\text{ mA}$, $V_O = 1.0\text{ V}$, $R_{ext} = 69\text{ k}\Omega$ at 10 mA | | ± 1.5 | ± 3.0 | % |
| dI_{OUT2} | Current skew (IC) | $I_{OUT} = 10.8\text{ mA}$, $V_O = 1.0\text{ V}$, $R_{ext} = 69\text{ k}\Omega$ at 10 mA | | ± 3.0 | ± 6.0 | % |
| $\%/dV_O$ | Output current vs. output voltage regulation | V_O within 1.0 V and 3.0 V, $R_{ext} = 34.7\text{ k}\Omega$ at 20 mA | | ± 0.1 | ± 0.5 | % / V |
| $\%/dV_{DD}$ | Output current vs. supply voltage regulation | V_{DD} within 3.0 V and 3.6 V | | ± 1.0 | ± 5.0 | % / V |
| $R_{IN(down)}$ | Pull-down resistor | LE | 150 | 200 | 250 | $\text{k}\Omega$ |
| $I_{DD(off)1}$ | Supply current "OFF" | $R_{ext} = \text{Open}$, $\overline{OUT0} \sim \overline{OUT15} = \text{Off}$ | | 7.2 | 9.3 | mA |
| $I_{DD(off)2}$ | | $I_O = 20\text{ mA}$, $\overline{OUT0} \sim \overline{OUT15} = \text{Off}$ | | 8.6 | 11 | |
| $I_{DD(off)3}$ | | $I_O = 60\text{ mA}$, $\overline{OUT0} \sim \overline{OUT15} = \text{Off}$ | | 11.7 | 15.2 | |
| $I_{DD(on)1}$ | Supply current "ON" | $I_O = 20\text{ mA}$, $\overline{OUT0} \sim \overline{OUT15} = \text{On}$ | | 29 | 37.7 | mA |
| $I_{DD(on)2}$ | | $I_O = 60\text{ mA}$, $\overline{OUT0} \sim \overline{OUT15} = \text{On}$ | | 31.2 | 40 | |

Figure 3. Test circuit for electrical characteristics

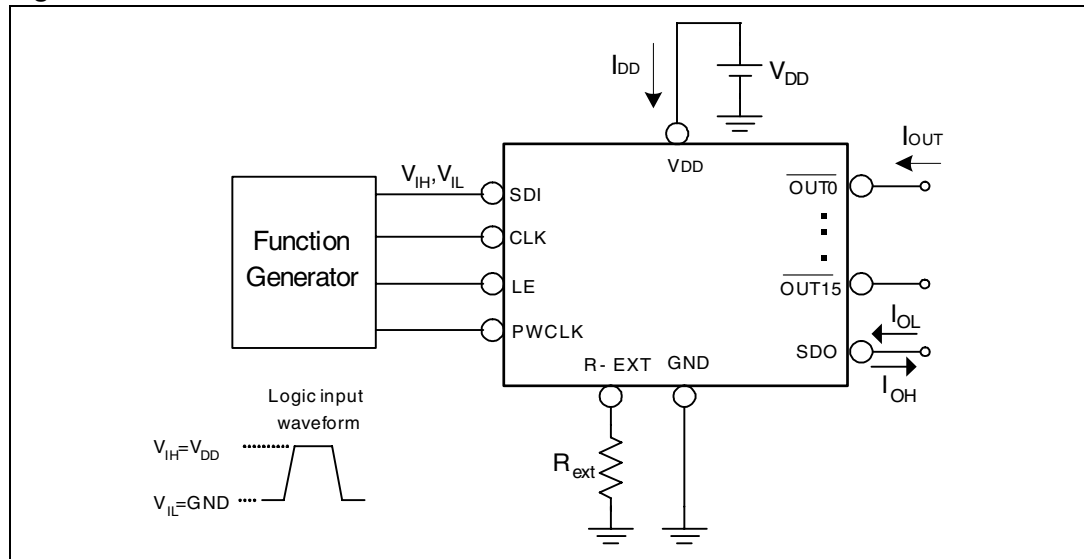

Table 10. Switching characteristics ($V_{DD} = 5.0\text{ V}$) $T_A = -40 \sim 125\text{ }^\circ\text{C}$

| Symbol | Characteristics | Conditions | Min. | Typ. | Max. | Unit |
|-----------------------|---|--|------|------|------|---------------|
| t_{SU0} | Setup time | SDI - CLK \uparrow | 1 | | | ns |
| t_{SU1} | | LE \uparrow - DCLK \uparrow | 1 | | | ns |
| t_{SU2} | | LE \downarrow - DCLK \uparrow | 5 | | | ns |
| t_{H0} | Hold time | CLK \uparrow - SDI | 3 | | | ns |
| t_{H1} | | CLK \uparrow - LE \downarrow | 7 | | | ns |
| t_{PD0} | Propagation delay time | CLK - SDO | | 30 | 40 | ns |
| t_{PD1} | | PWCLK - $\overline{\text{OUTn4}}$ ⁽¹⁾ | | 100 | | ns |
| t_{PD2} | | LE - SDO ⁽²⁾ | | 30 | 40 | ns |
| t_{DL1} | Stagger delay time | $\overline{\text{OUTn4}} + 1$ ⁽¹⁾ | | 40 | | ns |
| t_{DL2} | | $\overline{\text{OUTn4}} + 2$ ⁽¹⁾ | | 80 | | ns |
| t_{DL3} | | $\overline{\text{OUTn4}} + 3$ ⁽¹⁾ | | 120 | | ns |
| $t_{w(L)}$ | Pulse width | LE | 5 | | | ns |
| $t_{w(\text{CLK})}$ | | CLK | 20 | | | ns |
| $t_{w(\text{PWCLK})}$ | | PWCLK | 20 | | | ns |
| t_{ON} | Output rise time of output ports | | | 10 | | ns |
| t_{OFF} | Output fall time of output ports | | | 6 | | ns |
| t_{EDD} | Error detection minimum duration ⁽³⁾ | | | 1 | | μs |

1. Refer to the timing waveform, where n = 0, 1, 2, 3.
2. In timing of "read configuration" and "read error status code", the next CLK rising edge should be t_{PD2} after the falling edge of LE.
3. Refer to [Figure 5 on page 13](#).

Table 11. Switching characteristics ($V_{DD} = 3.3\text{ V}$)

| Symbol | Characteristics | Conditions | Min. | Typ. | Max. | Unit | |
|----------------|----------------------------------|---|--|------|------|---------------|----|
| t_{SU0} | Setup time | SDI - DCLK \uparrow | 1 | | | ns | |
| t_{SU1} | | LE \uparrow - DCLK \uparrow | 1 | | | ns | |
| t_{SU2} | | LE \downarrow - DCLK \uparrow | 5 | | | ns | |
| t_{H0} | Hold time | CLK \uparrow - SDI | 3 | | | ns | |
| t_{H1} | | CLK \uparrow - LE \downarrow | 7 | | | ns | |
| t_{PD0} | Propagation delay time | CLK - SDO | | 45 | 40 | ns | |
| t_{PD1} | | PWCLK- $\overline{\text{OUTn4}}$ ⁽¹⁾ | $V_{DD} = 3.3\text{ V}$ $V_{IH} = V_{DD}$ $V_{IL} = \text{GND}$ | | 120 | | ns |
| t_{PD2} | | LE - SDO ⁽²⁾ | $R_{ext} = 460\ \Omega$ | | 45 | 40 | ns |
| t_{DL1} | Stagger delay time | $\overline{\text{OUTn4}} + 1$ ⁽¹⁾ | | 40 | | ns | |
| t_{DL2} | | $\overline{\text{OUTn4}} + 2$ ⁽¹⁾ | $V_{LED} = 4.5\text{ V}$ $R_L = 152\ \Omega$ $CL = 10\text{ pF}$ | | 80 | | ns |
| t_{DL3} | | $\overline{\text{OUTn4}} + 3$ ⁽¹⁾ | $C1 = 100\text{ nF}$ $C2 = 10\ \mu\text{F}$ | | 120 | | ns |
| $t_{w(L)}$ | Pulse width | LE | 5 | | | ns | |
| $t_{w(CLK)}$ | | CLK | 20 | | | ns | |
| $t_{w(PWCLK)}$ | | PWCLK | 20 | | | ns | |
| t_{ON} | Output rise time of output ports | | | 11.6 | | ns | |
| t_{OFF} | Output fall time of output ports | | | 7 | | ns | |
| t_{DEC} | Error detection duration | | | 0.5 | 1 | μs | |

1. Refer to the timing waveform [Figure 4](#), where $n = 0, 1, 2, 3$.
2. In timing of “read configuration” and “read error status code”, the next CLK rising edge should be t_{PD2} after the falling edge of LE.

Figure 4. Test circuit for switching characteristics

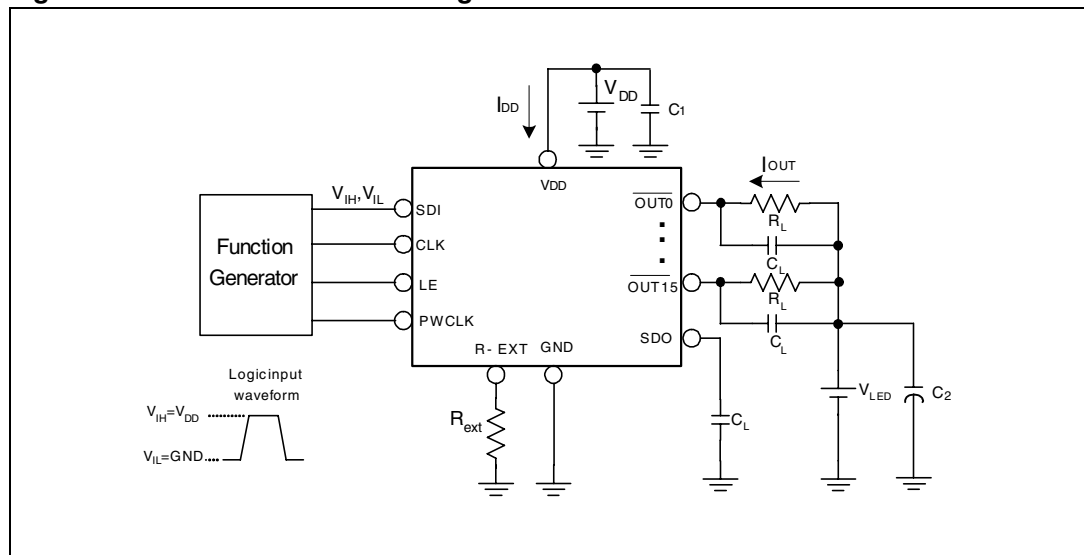

5 Timing waveform

Figure 5. Timing waveform

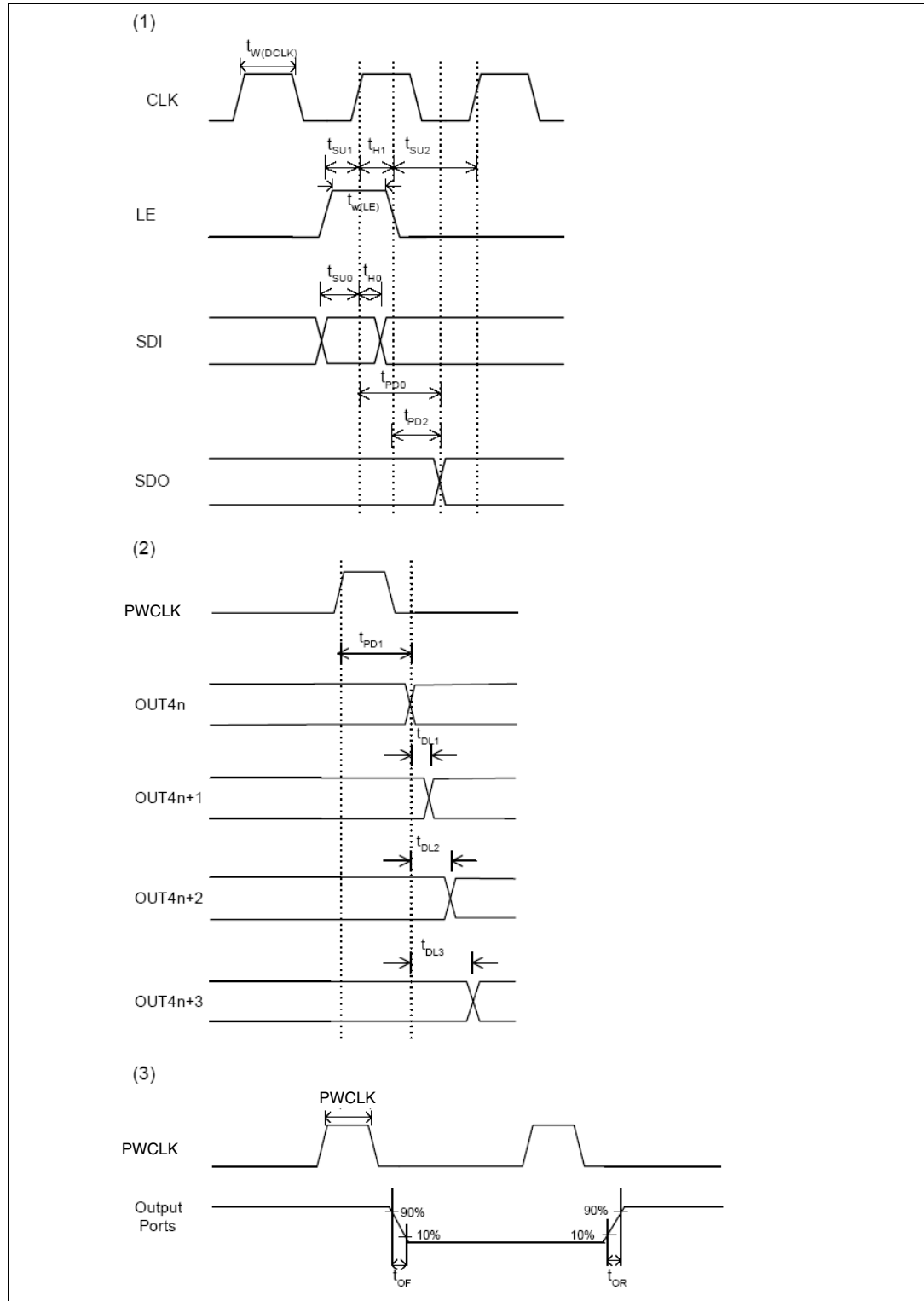

6 Principle of operation

Table 12. Control command

| Command name | Signals combination | | Description |
|---------------------------------------|---------------------|---|---|
| | LE | Number of CLK rising edge when LE is asserted | |
| Data latch | High | 1 | Serial data are transferred to the buffers |
| Global latch | High | 2 or 3 | Buffer data are transferred to the comparators |
| Read configuration | High | 4 or 5 | Move out "configuration register" to the shift register |
| Enable "error detection" | High | 6 or 7 | Detect the status of each output's LED |
| Read "error status code" | High | 8 or 9 | Move out "error status code" of 16 outputs to the shift registers |
| Write configuration | High | 10 or 11 | Serial data are transferred to the "configuration register" |
| Reset to 16-bit shift register length | High | 12 or 13 | Set to 16-bit the shift register length |

Figure 6. Timing diagram

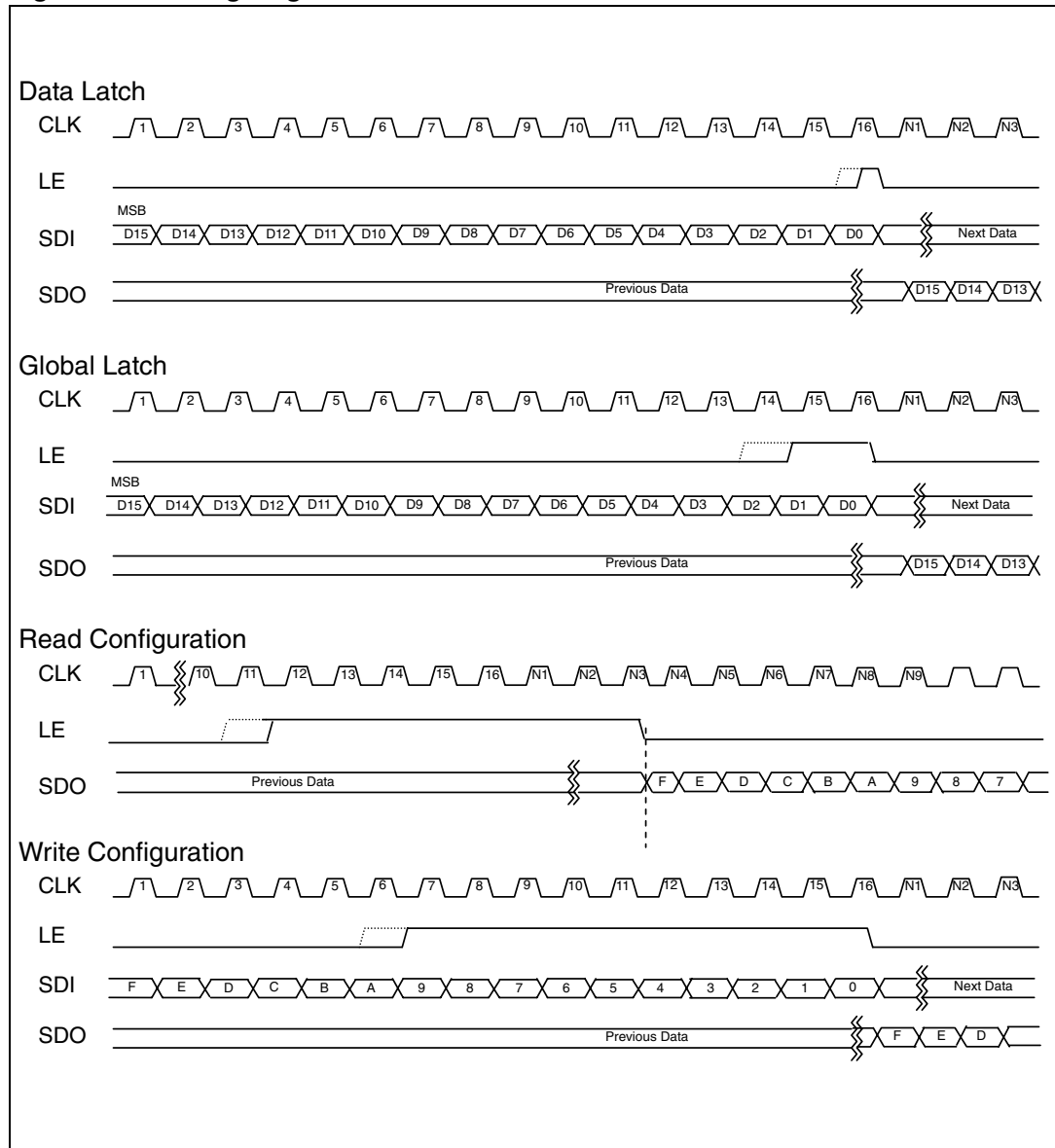

7 Definition of configuration register

Configuration register

| | | | | | | | | | | | | | | | |
|-----|---|---|---|---|---|---|---|---|---|---|---|---|---|-----|---|
| MSB | | | | | | | | | | | | | | LSB | |
| F | E | D | C | B | A | 9 | 8 | 7 | 6 | 5 | 4 | 3 | 2 | 1 | 0 |

Default value

| | | | | | | | | | | | | | | | |
|-----|---|---|----|---|---|-------------|---|---|---|---|---|---|---|-----|---|
| MSB | | | | | | | | | | | | | | LSB | |
| F | E | D | C | B | A | 9 | 8 | 7 | 6 | 5 | 4 | 3 | 2 | 1 | 0 |
| X | 0 | 1 | 11 | | 1 | 8'b10101011 | | | | | | | | 0 | 0 |

Table 13. Configuration register

| Bit | Attribute | Definition | Value | Function |
|--------------|------------|---------------------------------------|---|--|
| F | Read/Write | Shift register length | 0 (default) | Shift register length 0 = 16-bit, 1 = 256-bit |
| E | Read | Thermal error flag | 0 (default) | Safe (OK) |
| | | | 1 | Over temperature (>150 °C typ.) |
| D | Read/Write | PWM counter: 16-bit or 12-bit | 0 (default) | To set the gray scale mode (PWM): 0 = 12-bit 1 = 16-bit |
| C | Read/Write | PWM counting mode selection | 00 | 64 times of MSB ⁽¹⁾ 6-bit PWM counting plus once of LSB ⁽¹⁾ 6-bit PWM counting |
| | | | 01 | 16 times of MSB 6-bit PWM counting by 1/4 PWCLK plus once of LSB 6-bit PWM counting |
| 10 | | | 4 times of MSB 6-bit PWM counting by 1/16 PWCLK plus once of LSB 6-bit PWM counting | |
| 11 (default) | | | PWM counting | |
| A | Read/Write | PWM data synchronization mode | 0 | Auto-synchronization |
| | | | 1 (default) | Manual synchronization |
| 9~2 | Read/Write | Current gain adjustment | 00000000 ~ 11111111 | 8'b10101011 (default) |
| 1 | Read/Write | TSD thermal shutdown | 0 (default) | Disable |
| | | | 1 | Enable ⁽²⁾ the output channel turn OFF if T _{TF} > 150 °C |
| 0 | Read/Write | Time-out alert of PWCLK disconnection | 0 (default) | Enable ⁽³⁾ |
| | | | 1 | Disable |

1. Please refer to “setting the PWM counting mode” section.
2. Please refer to “TSD” thermal error flag and thermal shutdown “section.
3. Please refer to “time-out alert of PWCLK disconnection” section.

8 Grey scales data loading

The STP1612PW05 is able to manage a gray-scale depth of 12 or 16 bits for each output, exploiting an e-PWM algorithm.

The bit D of the configuration register is used to select the grey-scale loading. Its value can be set to "0" for 12 bits or "1" for 16 bits. By default, D is set to "0".

Loading of the data is performed through the serial input on a dedicated buffer and two different methods can be used.

With both methods, the first incoming data packet is relative to the output 15; the following packet is relative to the output 14 and so on up to the output 0.

If F="0", when a data packet has been loaded, the latch signal (LE) must become active for one CLK cycle (data latch). When the last data packet, relative to the output 0, has been loaded, the latch signal must be active for two CLK cycles (global latch) and all the data will be transferred to the e-PWM registers starting from the MSB.

If F="1" all data packets (12 or 16 bits x16) are loaded and then the global latch signal must be active and all the data will be transferred to the e-PWM registers starting from the MSB.

Figure 7. Full timing for data loading

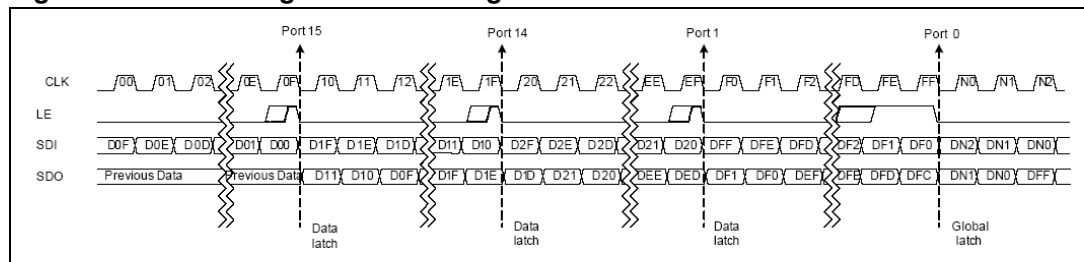

9 Setting the PWM gray scale counter

STP1612PW05 provides a 12-bit or 16-bit PWM color depth. Each serial data input will be implemented according to the e-PWM algorithm.

9.1 PWM data synchronization

STP1612PW05 defines the different counting algorithms that support e-PWM, technology, (scrambled PWM). With e-PWM, the total PWM cycles can be broken down into MSB (most significant bits) and LSB (least significant bits) of gray scale cycles, and the MSB information can be dithered across many refresh cycles to achieve overall same high bit resolution. STP1612PW05 also allows changing different counting algorithms and provides the best output linearity when there are fewer transitions of output.

Figure 8. 12-bit e-PWM operation example

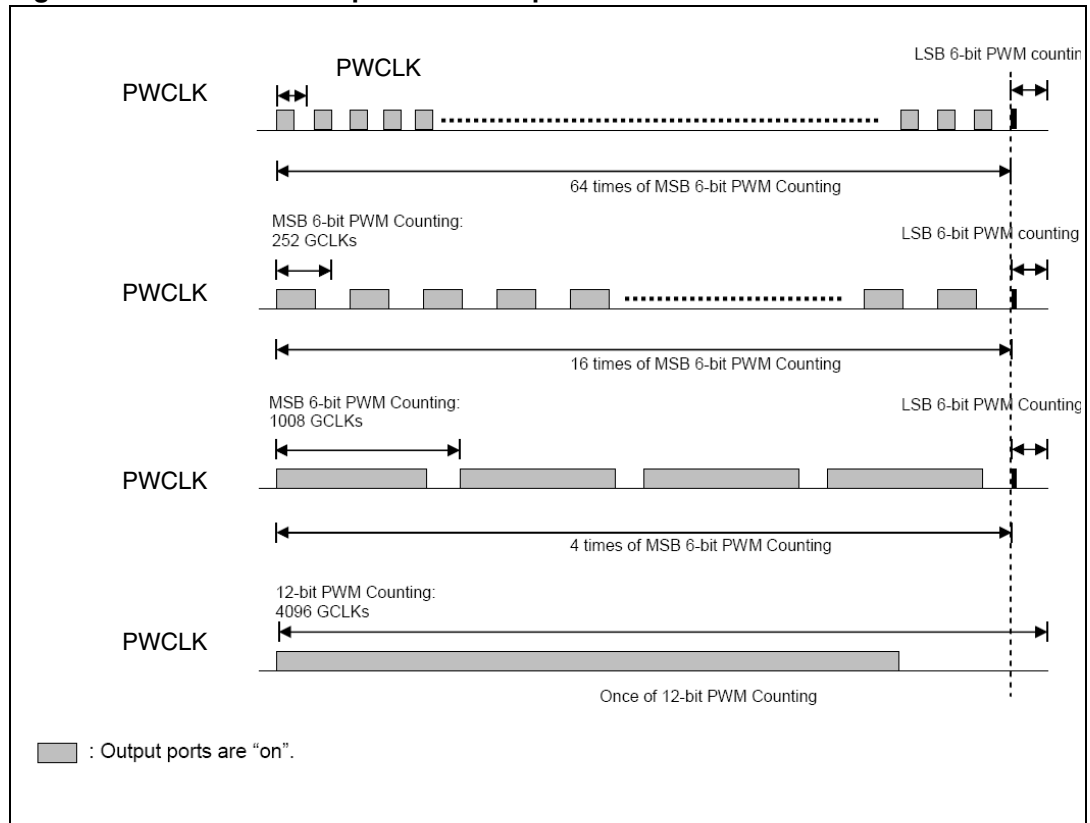

9.2 Synchronization for PWM counting

The data synchronization between the incoming data flow and the output channels is managed through the bit A within the configuration register.

If the bit A is set to “0” the device performs itself the data synchronization: when all the new data are loaded with a “global latch”, the device wait until all the PWM counter completes the counting cycle before updating them with the new data, at the next CLK rising edge.

Conversely, if bit A is set to “1” (default), the data synchronization is not performed by the device and is managed by the microcontroller, which has to take care of the data and signals. If this is not done, there might be artefacts on the output image.

Figure 9. Synchronization for PWM counting

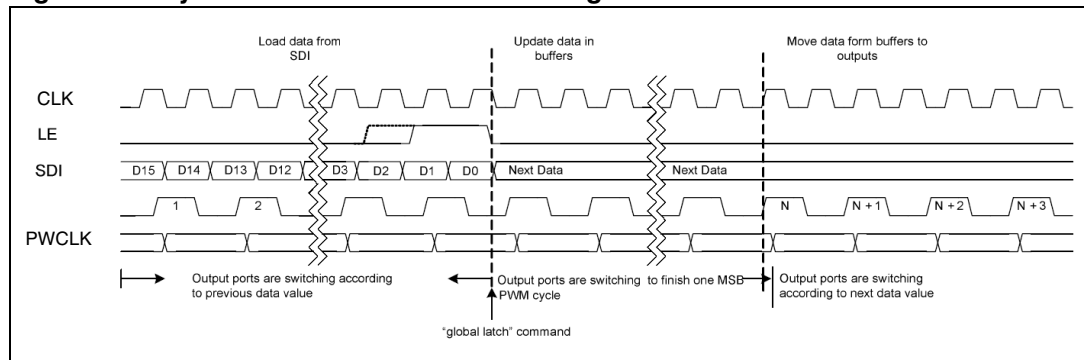
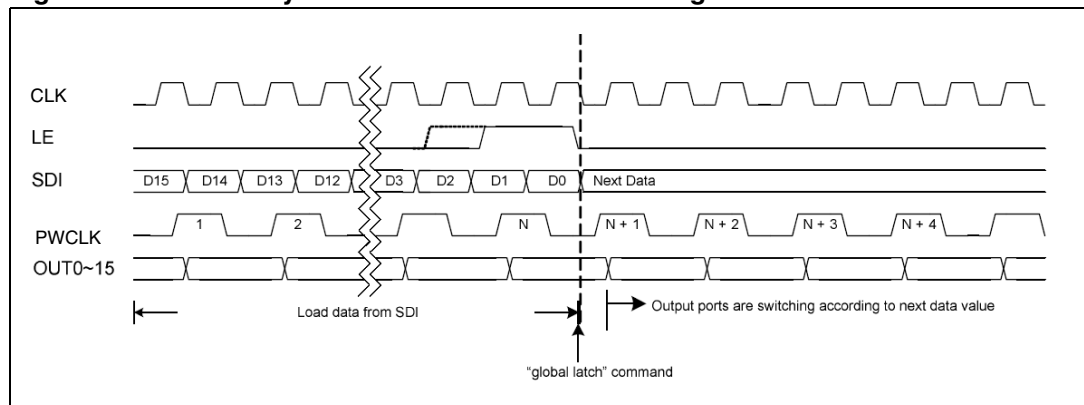

Figure 10. Without synchronization for PWM counting



10 Error detection conditions

The STP1612PW05 can detect open channels (OD) and LED short-circuits (SD).

The detection circuitry performs open- and short-circuit detection simultaneously and the image quality will not be impacted since the test duration is short (0.5 μ s typ).

To perform the open-circuit, short-circuit error detection a channel must be on, the command “enable error detection” starts the detection. After 0.5 μ s (typ) the command “read error status code” allows to get the status from the serial output (SDO).

Table 14. Detection conditions ($V_{DD} = 3.3$ to 5 V temp. range -40 to 125 °C)

| | | |
|----------------------|---|---|
| SW-1 or SW-3b | Open line or output short to GND detected | $\implies I_{ODEC} \leq 0.5 \times I_O$ |
| SW-2 or SW-3a | Short on LED or short to V-LED detected | $\implies V_O \geq 2.3$ V |

Note: Where: I_O = the output current programmed by the R_{EXT} ; I_{ODEC} = the detected output current in detection mode

Figure 11. Detection circuit

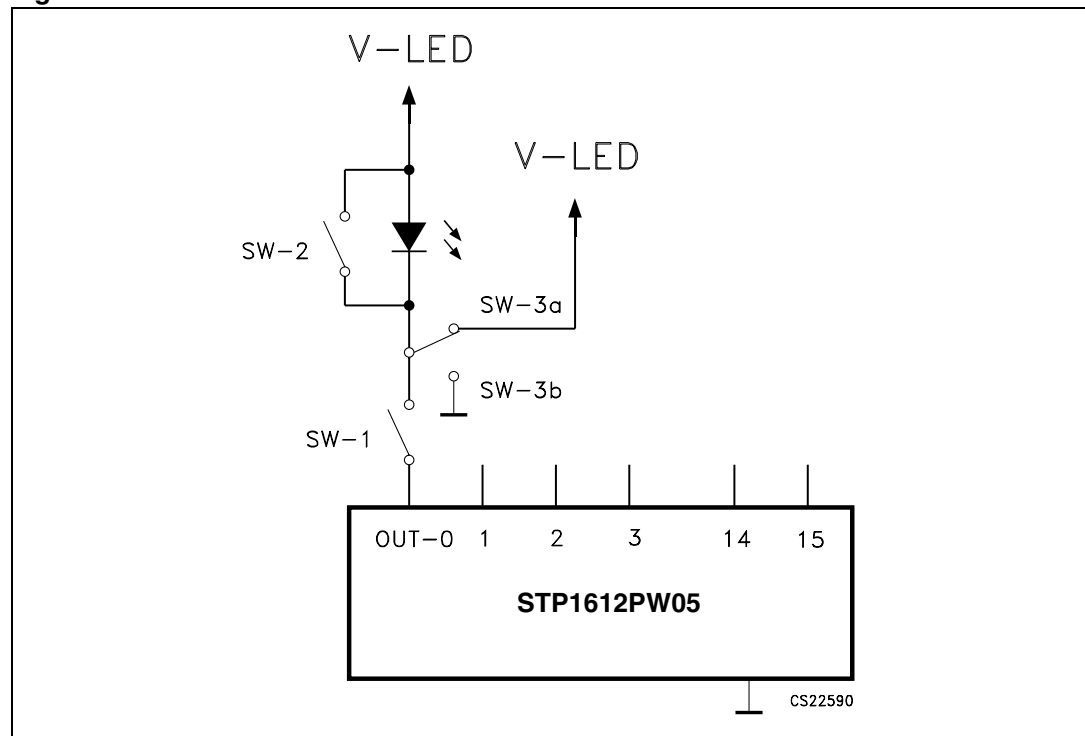

11 Setting output current

The output current (I_{OUT}) is set by an external resistor, R_{EXT} .

It is calculated from the equation:

$$V_{R-EXT} = 1.24 \times G; I_{OUT} = (V_{R-EXT}/R_{EXT}) \times 15.5$$

Whereas R_{EXT} is the resistance of the external resistor connected to R-EXT terminal and V_{R-EXT} is its voltage. G is the digital current gain, which is set by the bit9 – bit2 of the configuration register. The default value of G is 1. For your information, the output current is about 20 mA when $R_{EXT} = 34.70 \text{ k}\Omega$ and 10 mA when $R_{EXT} = 69.6 \text{ k}\Omega$ if G is set to default value 1. The formula and setting for G are described in next section.

Figure 12. Rext vs output current

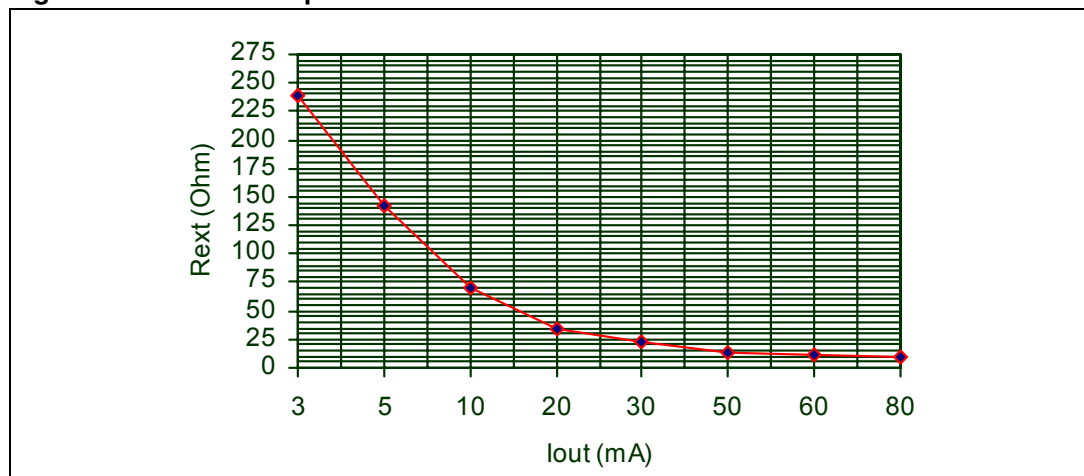

Table 15. Rext vs output current (1)

| Iout (mA) | Rext (kΩ) |
|-----------|-----------|
| 3 | 238.2 |
| 5 | 142.2 |
| 10 | 69.6 |
| 20 | 34.70 |
| 30 | 22.94 |
| 50 | 13.72 |
| 60 | 11.40 |
| 80 | 8.63 |

1. $T_A = 25 \text{ }^\circ\text{C}$, $V_{dd} = 3.3 \text{ V}; 5.0 \text{ V}$, $V_{Led} = 3.0 \text{ V}$, $V_{drop} = 1.5 \text{ V}$, HC = 0101011 (default)

12 Current gain adjustment

Figure 13. Gain vs DA6 - DA0

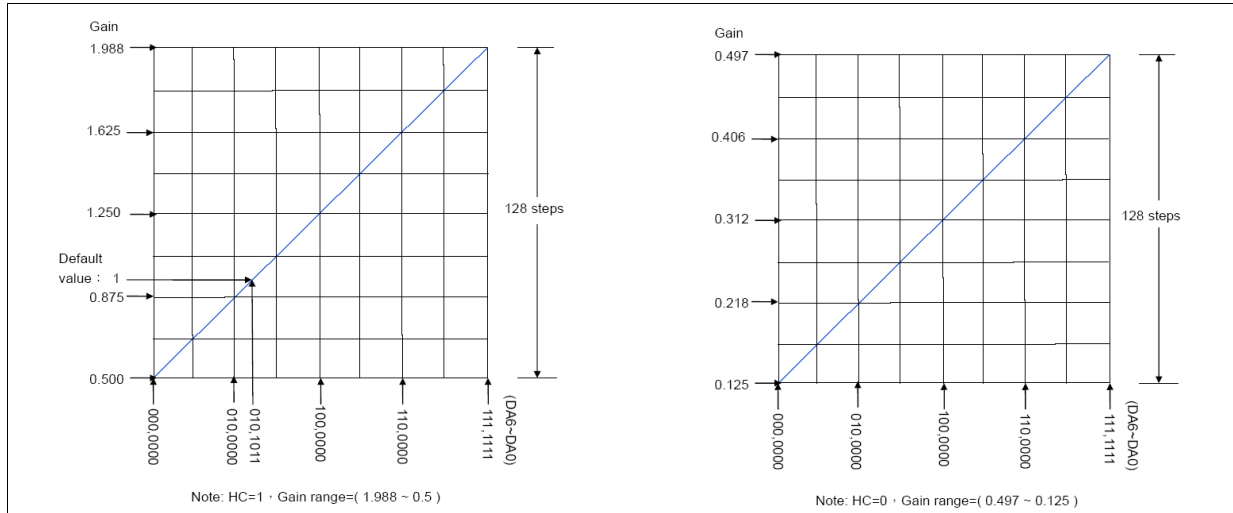

The bit 9 to bit 2 of the configuration register set the gain of output current, i.e., G. Being 8-bit in total, ranging from 8'b00000000 to 8'b11111111, these bits allow the user to set the output current gain up to 256 levels. These bits can be further defined in the configuration register as follows:

Configuration register

| MSB | | | | | | | | | | | | | | | | LSB | |
|-----|---|---|---|---|---|----|-----|-----|-----|-----|-----|-----|-----|---|---|-----|--|
| F | E | D | C | B | A | 9 | 8 | 7 | 6 | 5 | 4 | 3 | 2 | 1 | 0 | | |
| - | - | - | - | - | - | HC | DA6 | DA5 | DA4 | DA3 | DA2 | DA1 | DA0 | - | - | | |

1. Bit 9 is HC bit. The setting is in the low current range when HC=0, and in the high current range when HC=1.
2. Bit 8 to bit 2 are DA6 ~ DA0.

The relationship between these bits and current gain G is:

$$HC = 1, D = (256G-128)/3$$

$$HC = 0, D = (1024G-128)/3$$

and D in the above decimal numeration can be converted to its equivalent in binary form by the following equation:

$$D = DA6x2^6 + DA5x2^5 + DA4x2^4 + DA3x2^3 + DA2x2^2 + DA1x2^1 + DA0x2^0$$

In other words, these bits can be looked as a floating number with 1-bit exponent HC and 7-bit mantissa DA6~DA0.

For example,

$$HC = 1, G = 1.25, D = (256 \times 1.25 - 128) / 3 = 64$$

the D in binary form would be:

$$D = 64 = 1 \times 2^6 + 0 \times 2^5 + 0 \times 2^4 + 0 \times 2^3 + 0 \times 2^2 + 0 \times 2^1 + 0 \times 2^0$$

The bit 9 to bit 2 of the configuration register are set to 8'b1100,0000.

13 Delay time of staggered output

This feature prevents large inrush current from the power line and reduces the bypass capacitors.

The outputs are organized in four groups OUT4n, OUT4n+1, OUTn4+2, OUT4n+3 and each group has 40 ns delay between the previous one.

E.g.: OUT4n has no delay, OUTn4+1 has 40ns delay, OUTn4+2 has 80ns delay, OUTn4+3 has 120 ns delay.

14 Thermal protection

Thermal flag provides an indication about the status of the junction temperature. When the junction temperature reaches 150 °C the bit E of the configuration register is set to "1", signaling dangerous operating condition. This flag is useful when thermal shutdown function is disabled.

The thermal shutdown function, if activated by configuration register, turns-off all output channels if the junction exceeds 150 °C. As soon as the junction temperature is below 140 °C the outputs channels will be turned ON. In thermal shutdown mode, the digital core is active and data flow is guaranteed.

15 Time-out alert of GCLK disconnection

When the PWCLK signal is disconnected for around 1 second, all output ports will be turned off automatically. This function will protect the LED display system from staying ON indefinitely and prevent excessive current from damaging the power system. The default is set to 'enable' when bit "0" is 0. When the PWCLK is active again and new serial data are moved in, the driver resumes to work after resetting the internal counters and comparators.

Figure 14. Time-out alert application scheme

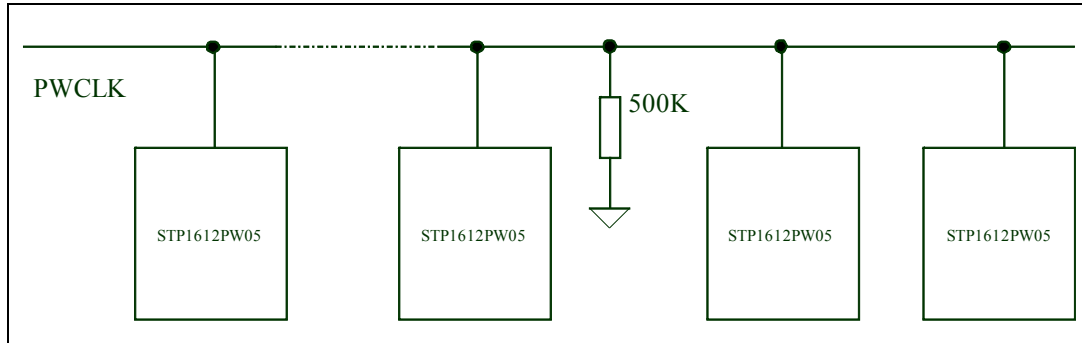

16 Package mechanical data

In order to meet environmental requirements, ST offers these devices in different grades of ECOPACK® packages, depending on their level of environmental compliance. ECOPACK® specifications, grade definitions and product status are available at: www.st.com. ECOPACK is an ST trademark.

Table 16. TSSOP24 mechanical data

| Dim. | mm. | | | inch | | |
|------|------|----------|------|--------|------------|--------|
| | Min. | Typ | Max. | Min. | Typ. | Max. |
| A | | | 1.1 | | | 0.043 |
| A1 | 0.05 | | 0.15 | 0.002 | | 0.006 |
| A2 | | 0.9 | | | 0.035 | |
| b | 0.19 | | 0.30 | 0.0075 | | 0.0118 |
| c | 0.09 | | 0.20 | 0.0035 | | 0.0079 |
| D | 7.7 | | 7.9 | 0.303 | | 0.311 |
| E | 4.3 | | 4.5 | 0.169 | | 0.177 |
| e | | 0.65 BSC | | | 0.0256 BSC | |
| H | 6.25 | | 6.5 | 0.246 | | 0.256 |
| K | 0° | | 8° | 0° | | 8° |
| L | 0.50 | | 0.70 | 0.020 | | 0.028 |

Figure 15. TSSOP24 package dimensions

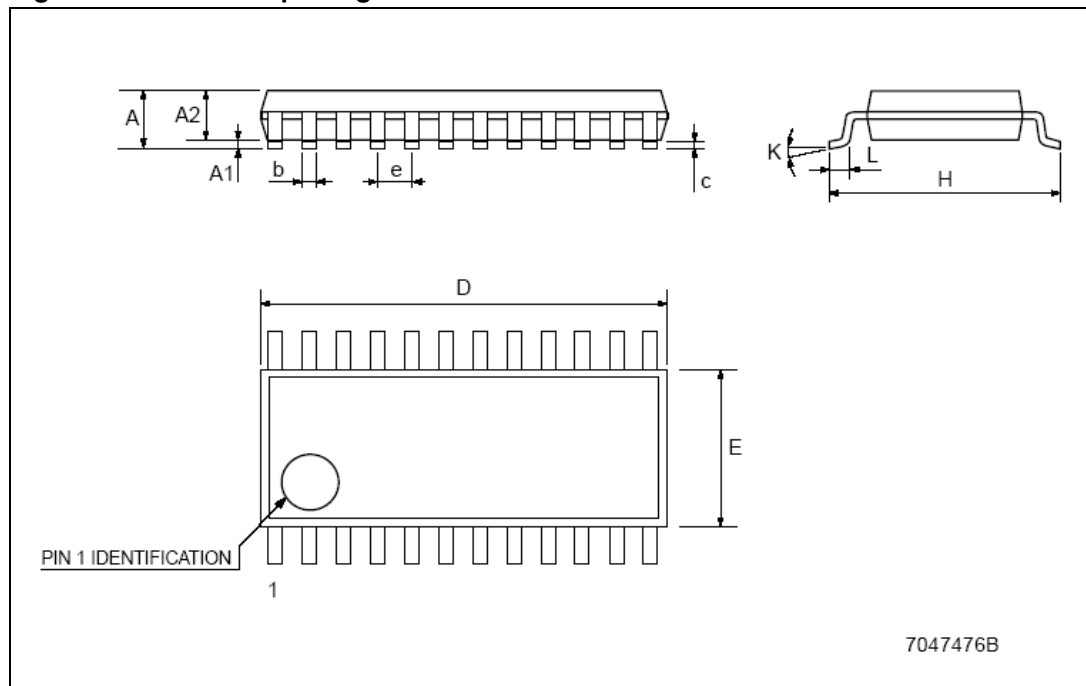

Table 17. TSSOP24 tape and reel

| Dim. | mm. | | | inch | | |
|------|------|-----|------|-------|------|--------|
| | Min. | Typ | Max. | Min. | Typ. | Max. |
| A | | - | 330 | | - | 12.992 |
| C | 12.8 | - | 13.2 | 0.504 | - | 0.519 |
| D | 20.2 | - | | 0.795 | - | |
| N | 60 | - | | 2.362 | - | |
| T | | - | 22.4 | | - | 0.882 |
| Ao | 6.8 | - | 7 | 0.268 | - | 0.276 |
| Bo | 8.2 | - | 8.4 | 0.323 | - | 0.331 |
| Ko | 1.7 | - | 1.9 | 0.067 | - | 0.075 |
| Po | 3.9 | - | 4.1 | 0.153 | - | 0.161 |
| P | 11.9 | - | 12.1 | 0.468 | - | 0.476 |

Figure 16. TSSOP24 reel dimensions

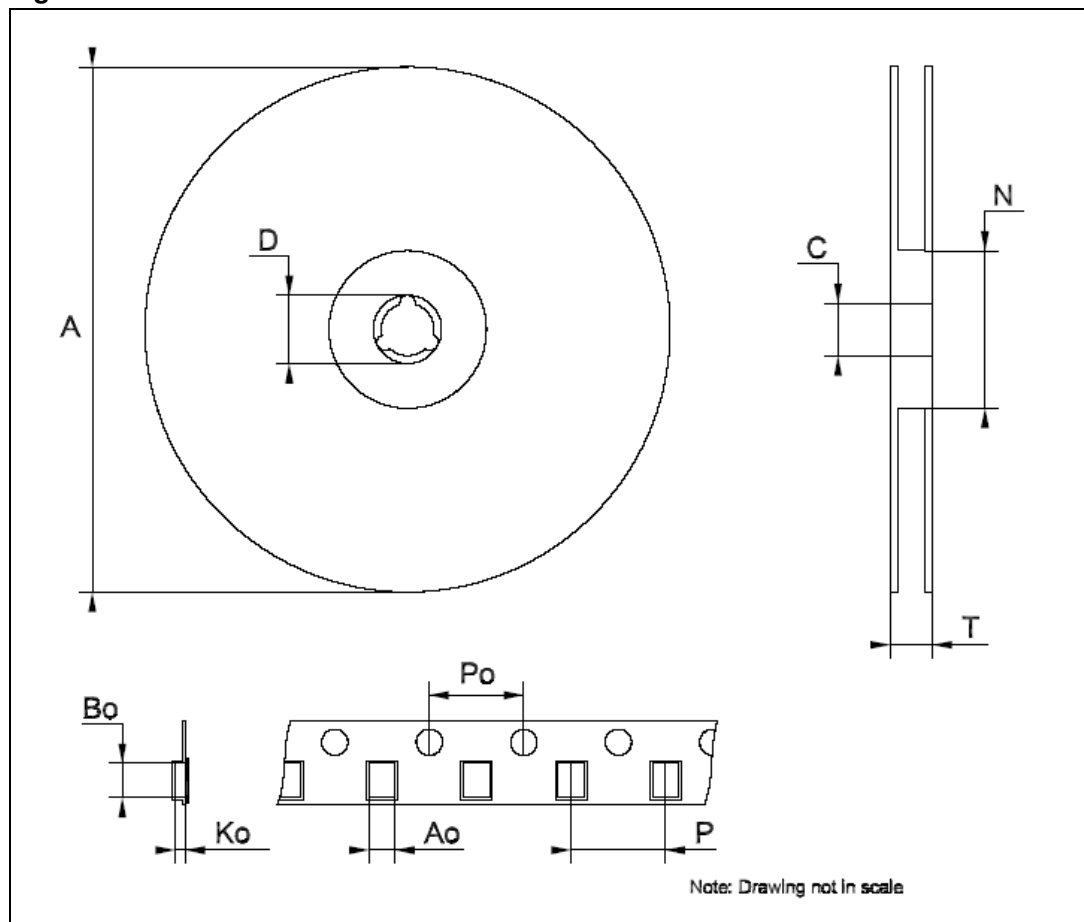

Table 18. SO-24 mechanical data

| Dim. | mm. | | | inch | | |
|------|-----------|-------|-------|-------|-------|-------|
| | Min. | Typ | Max. | Min. | Typ. | Max. |
| A | | | 2.65 | | | 0.104 |
| a1 | 0.1 | | 0.2 | 0.004 | | 0.008 |
| a2 | | | 2.45 | | | 0.096 |
| b | 0.35 | | 0.49 | 0.014 | | 0.019 |
| b1 | 0.23 | | 0.32 | 0.009 | | 0.012 |
| C | | 0.5 | | | 0.020 | |
| c1 | 45°(typ.) | | | | | |
| D | 15.20 | | 15.60 | 0.598 | | 0.614 |
| E | 10.00 | | 10.65 | 0.393 | | 0.419 |
| e | | 1.27 | | | 0.050 | |
| e3 | | 13.97 | | | 0.550 | |
| F | 7.40 | | 7.60 | 0.291 | | 0.300 |
| L | 0.50 | | 1.27 | 0.020 | | 0.050 |
| S | °(max.) 8 | | | | | |

Figure 17. SO-24 package dimensions

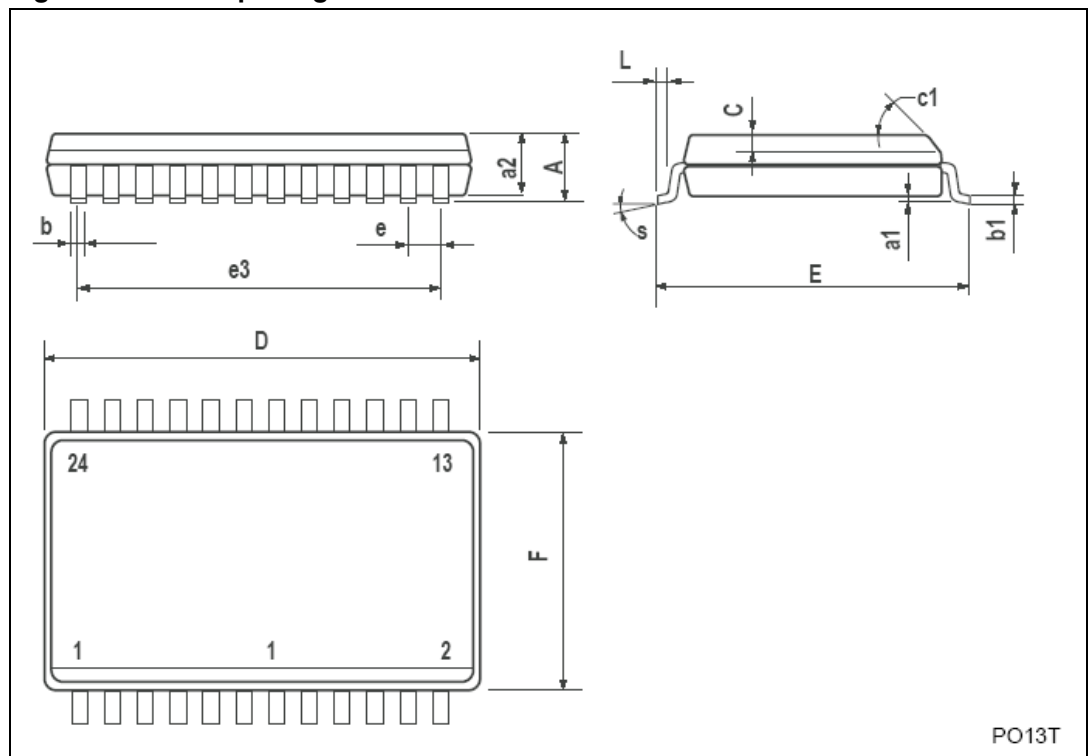

Table 19. SO-24 tape and reel

| Dim. | mm. | | | inch | | |
|------|------|-----|------|-------|------|--------|
| | Min. | Typ | Max. | Min. | Typ. | Max. |
| A | | - | 330 | | - | 12.992 |
| C | 12.8 | - | 13.2 | 0.504 | - | 0.519 |
| D | 20.2 | - | | 0.795 | - | |
| N | 60 | - | | 2.362 | - | |
| T | | - | 30.4 | | - | 1.197 |
| Ao | 10.8 | - | 11.0 | 0.425 | - | 0.433 |
| Bo | 15.7 | - | 15.9 | 0.618 | - | 0.626 |
| Ko | 2.9 | - | 3.1 | 0.114 | - | 0.122 |
| Po | 3.9 | - | 4.1 | 0.153 | - | 0.161 |
| P | 11.9 | - | 12.1 | 0.468 | - | 0.476 |

Figure 18. SO-24 reel dimensions

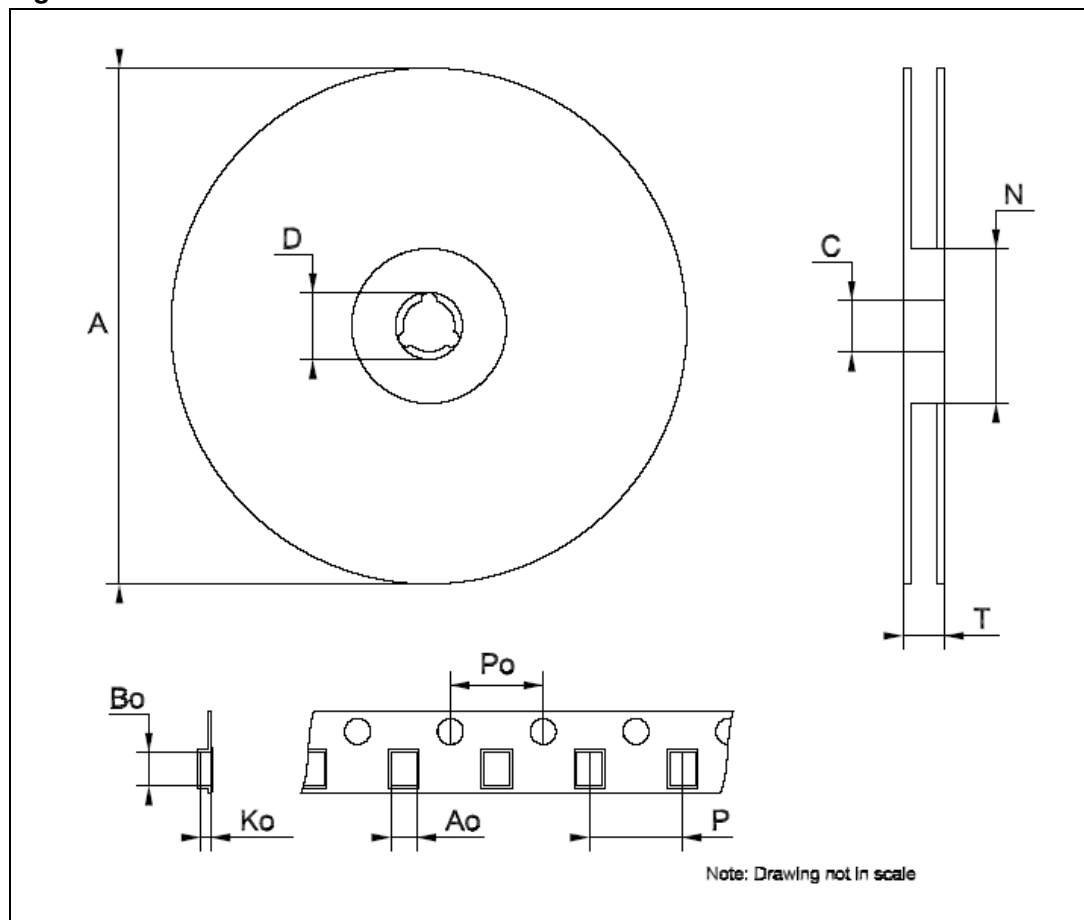

Table 20. TSSOP24 exposed-pad

| Dim. | mm | | | inch | | |
|------|------|------|------|-------|--------|--------|
| | Min. | Typ. | Max. | Min. | Typ. | Max. |
| A | | | 1.2 | | | 0.047 |
| A1 | | | 0.15 | 0.004 | | 0.006 |
| A2 | 0.8 | 1 | 1.05 | 0.031 | 0.039 | 0.041 |
| b | 0.19 | | 0.30 | 0.007 | | 0.012 |
| c | 0.09 | | 0.20 | 0.004 | | 0.0089 |
| D | 7.7 | 7.8 | 7.9 | 0.303 | 0.307 | 0.311 |
| D1 | 4.7 | 5.0 | 5.3 | 0.185 | 0.197 | 0.209 |
| E | 6.2 | 6.4 | 6.6 | 0.244 | 0.252 | 0.260 |
| E1 | 4.3 | 4.4 | 4.5 | 0.169 | 0.173 | 0.177 |
| E2 | 2.9 | 3.2 | 3.5 | 0.114 | 0.126 | 0.138 |
| e | | 0.65 | | | 0.0256 | |
| K | 0° | | 8° | 0° | | 8° |
| L | 0.45 | 0.60 | 0.75 | 0.018 | 0.024 | 0.030 |

Figure 19. TSSOP24 package dimensions

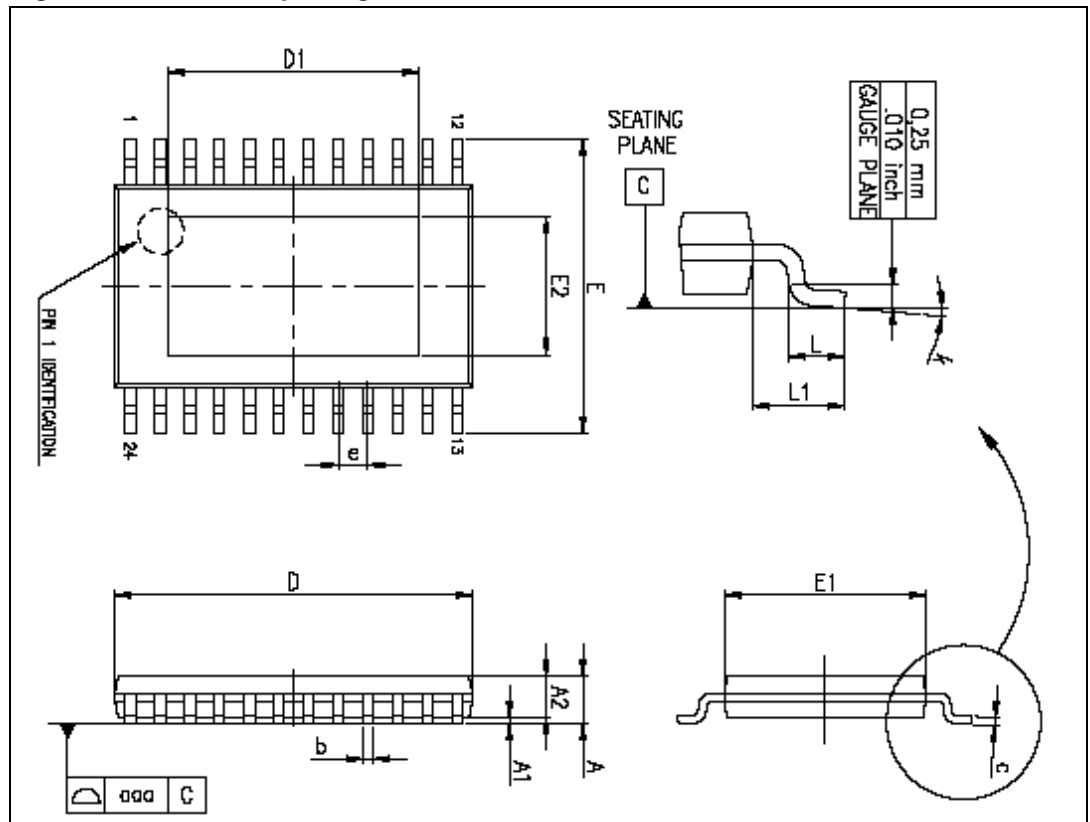
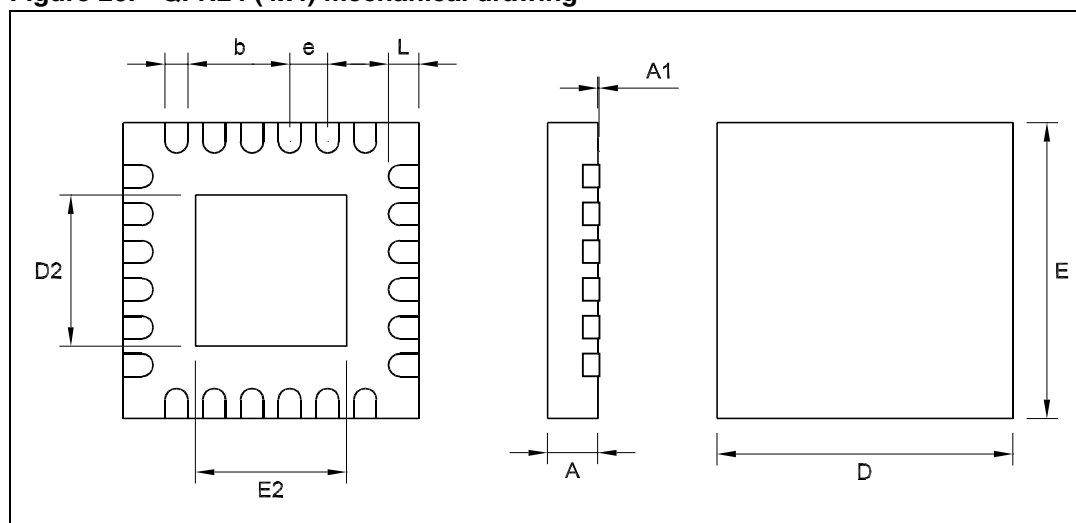

Table 21. QFN24 (4x4) mechanical data

| Dim. | mm. | | | mils | | |
|------|------|------|------|-------|------|-------|
| | Min. | Typ | Max. | Min. | Typ. | Max. |
| A | | | 1.00 | | | 39.4 |
| A1 | 0.00 | | 0.05 | 0.0 | | 2.0 |
| b | 0.18 | | 0.30 | 7.1 | | 11.8 |
| D | 3.9 | | 4.1 | 153.5 | | 161.4 |
| D2 | 2.6 | | 2.8 | 76.8 | | 88.6 |
| E | 3.9 | | 4.1 | 153.5 | | 161.4 |
| E2 | 2.6 | | 2.8 | 76.8 | | 88.6 |
| e | | 0.50 | | | 19.7 | |
| L | 0.40 | | 0.60 | 15.7 | | 23.6 |

Figure 20. QFN24 (4x4) mechanical drawing



Tape & Reel QFNxx/DFNxx (4x4) MECHANICAL DATA

| DIM. | mm. | | | inch | | |
|------|------|------|------|-------|-------|--------|
| | MIN. | TYP. | MAX. | MIN. | TYP. | MAX. |
| A | | | 330 | | | 12.992 |
| C | 12.8 | | 13.2 | 0.504 | | 0.519 |
| D | 20.2 | | | 0.795 | | |
| N | 99 | | 101 | 3.898 | | 3.976 |
| T | | | 14.4 | | | 0.567 |
| Ao | | 4.35 | | | 0.171 | |
| Bo | | 4.35 | | | 0.171 | |
| Ko | | 1.1 | | | 0.043 | |
| Po | | 4 | | | 0.157 | |
| P | | 8 | | | 0.315 | |

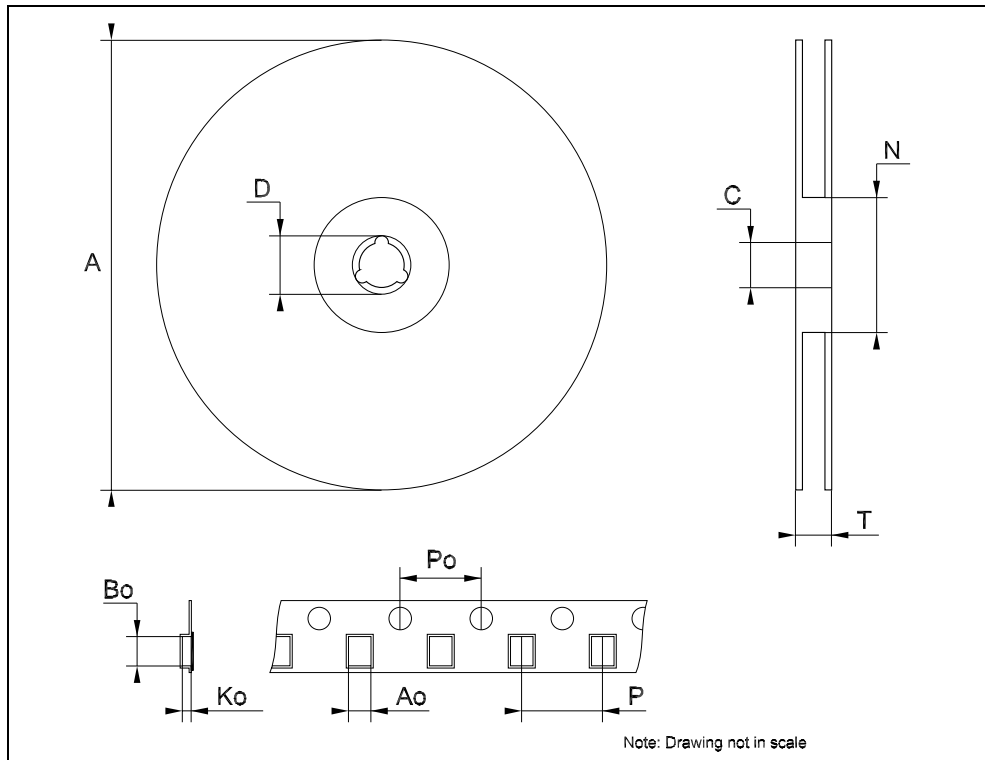

17 Revision history

Table 22. Document revision history

| Date | Revision | Changes |
|-------------|----------|--|
| 17-Jun-2009 | 1 | Initial release. |
| 10-Aug-2009 | 2 | Updated Section 9.2 on page 19 and Table 12 on page 14 |
| 29-Oct-2009 | 3 | Updated: Figure 2 on page 6 and Table 21 on page 30 Added: Figure 14 on page 24 |

Please Read Carefully:

Information in this document is provided solely in connection with ST products. STMicroelectronics NV and its subsidiaries ("ST") reserve the right to make changes, corrections, modifications or improvements, to this document, and the products and services described herein at any time, without notice.

All ST products are sold pursuant to ST's terms and conditions of sale.

Purchasers are solely responsible for the choice, selection and use of the ST products and services described herein, and ST assumes no liability whatsoever relating to the choice, selection or use of the ST products and services described herein.

No license, express or implied, by estoppel or otherwise, to any intellectual property rights is granted under this document. If any part of this document refers to any third party products or services it shall not be deemed a license grant by ST for the use of such third party products or services, or any intellectual property contained therein or considered as a warranty covering the use in any manner whatsoever of such third party products or services or any intellectual property contained therein.

UNLESS OTHERWISE SET FORTH IN ST'S TERMS AND CONDITIONS OF SALE ST DISCLAIMS ANY EXPRESS OR IMPLIED WARRANTY WITH RESPECT TO THE USE AND/OR SALE OF ST PRODUCTS INCLUDING WITHOUT LIMITATION IMPLIED WARRANTIES OF MERCHANTABILITY, FITNESS FOR A PARTICULAR PURPOSE (AND THEIR EQUIVALENTS UNDER THE LAWS OF ANY JURISDICTION), OR INFRINGEMENT OF ANY PATENT, COPYRIGHT OR OTHER INTELLECTUAL PROPERTY RIGHT.

UNLESS EXPRESSLY APPROVED IN WRITING BY AN AUTHORIZED ST REPRESENTATIVE, ST PRODUCTS ARE NOT RECOMMENDED, AUTHORIZED OR WARRANTED FOR USE IN MILITARY, AIR CRAFT, SPACE, LIFE SAVING, OR LIFE SUSTAINING APPLICATIONS, NOR IN PRODUCTS OR SYSTEMS WHERE FAILURE OR MALFUNCTION MAY RESULT IN PERSONAL INJURY, DEATH, OR SEVERE PROPERTY OR ENVIRONMENTAL DAMAGE. ST PRODUCTS WHICH ARE NOT SPECIFIED AS "AUTOMOTIVE GRADE" MAY ONLY BE USED IN AUTOMOTIVE APPLICATIONS AT USER'S OWN RISK.

Resale of ST products with provisions different from the statements and/or technical features set forth in this document shall immediately void any warranty granted by ST for the ST product or service described herein and shall not create or extend in any manner whatsoever, any liability of ST.

ST and the ST logo are trademarks or registered trademarks of ST in various countries.

Information in this document supersedes and replaces all information previously supplied.

The ST logo is a registered trademark of STMicroelectronics. All other names are the property of their respective owners.

© 2009 STMicroelectronics - All rights reserved

STMicroelectronics group of companies

Australia - Belgium - Brazil - Canada - China - Czech Republic - Finland - France - Germany - Hong Kong - India - Israel - Italy - Japan - Malaysia - Malta - Morocco - Philippines - Singapore - Spain - Sweden - Switzerland - United Kingdom - United States of America

www.st.com

