



# STM8T141

## Single-channel capacitive sensor for touch or proximity detection with shielded sensing electrode

### Features

- Touch or proximity detection (a few centimeters)
- Built-in driven shield function:
  - Enhance proximity detection
  - Protect sensing electrode from noise interference
- Ultra-low power modes suitable for battery applications (11  $\mu$ A in extreme low power mode)
- On-chip integrated voltage regulator
- Environment compensation filter
- User programmable options include:
  - Four detection thresholds
  - Four output modes
  - Four low power modes
  - Reference freeze timeout
- Minimal external components

### Applications

- Consumer electronics
- Power-critical and battery applications
  - Wake-up on proximity
- Home and office appliances
  - Find-in-the-dark (FITD) applications using proximity detection
  - Sanitary ware and white goods
- Flameproof human interface devices for use in hazardous environments

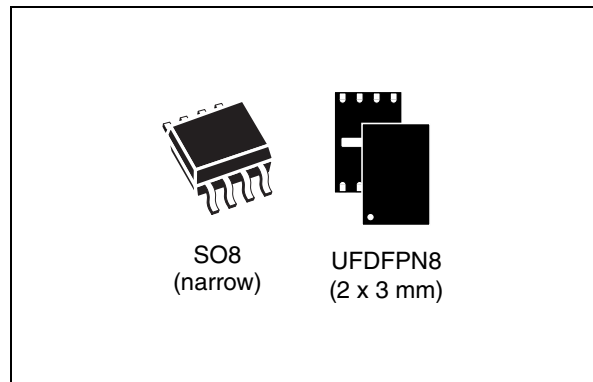

**Table 1. Device summary**

Feature	STM8T141
Operating supply voltage	2.0 V to 5.5 V
Supported interface	Single key state output
Operating temperature	–40° to +85 °C
Packages	8-pin SO 8-pin UFDFPN

# Contents

- 1 Description . . . . . 7**
- 2 Block diagram . . . . . 8**
- 3 Pin descriptions . . . . . 9**
- 4 STM8T ProxSense technology . . . . . 10**
  - 4.1 Capacitive sensing overview . . . . . 10
  - 4.2 Charge transfer acquisition principle . . . . . 10
- 5 STM8T processing . . . . . 12**
  - 5.1 Signal and reference calculation . . . . . 12
  - 5.2 Determining touch/proximity . . . . . 12
  - 5.3 Environment compensation filter (ECF) . . . . . 13
    - 5.3.1 ECF principle . . . . . 13
    - 5.3.2 Reference freeze timeout . . . . . 15
    - 5.3.3 Debounce filter . . . . . 16
- 6 Typical application diagram . . . . . 17**
- 7 Device operation . . . . . 18**
  - 7.1 Option byte description . . . . . 18
  - 7.2 TOUT/POUT output mode . . . . . 20
    - 7.2.1 Active . . . . . 20
    - 7.2.2 Toggle . . . . . 21
    - 7.2.3 3-second latch . . . . . 21
    - 7.2.4 30-second latch . . . . . 22
  - 7.3 Detection threshold . . . . . 22
  - 7.4 Power modes . . . . . 23
    - 7.4.1 Normal Power mode . . . . . 23
    - 7.4.2 Low Power mode with Zoom . . . . . 24
    - 7.4.3 Extreme Low Power mode with Zoom . . . . . 24
    - 7.4.4 Extreme Low Power mode . . . . . 25
  - 7.5 Charge transfer frequency . . . . . 25

7.6	Sampling period	25
<b>8</b>	<b>Design guidelines</b>	<b>26</b>
8.1	Shield function	26
8.1.1	Shield application example	26
8.2	Sensitivity adjustment	27
8.2.1	C <sub>S</sub> influence on sensitivity	27
8.2.2	PCB layout and construction	27
8.3	Influence of power supply variation	28
<b>9</b>	<b>Electrical characteristics</b>	<b>29</b>
9.1	Parameter conditions	29
9.1.1	Minimum and maximum values	29
9.1.2	Typical values	29
9.1.3	Typical curves	29
9.1.4	Loading capacitor	29
9.2	Absolute maximum ratings	30
9.3	Operating conditions	30
9.3.1	General operating conditions and supply characteristics	30
9.3.2	Average current consumption	31
9.3.3	Output characteristics	32
9.4	Regulator and reference voltage	32
9.5	Capacitive sensing characteristics	33
9.6	EMC characteristics	35
9.6.1	Functional EMS (electromagnetic susceptibility)	35
9.6.2	Prequalification trials	35
9.6.3	Electromagnetic interference (EMI)	36
9.6.4	Absolute maximum ratings (electrical sensitivity)	36
9.6.5	Electrostatic discharge (ESD)	36
9.6.6	Static latchup	37
<b>10</b>	<b>Package characteristics</b>	<b>38</b>
10.1	Package mechanical data	38
10.1.1	SO8 package mechanical data	38
10.1.2	UFD8 package mechanical data	40
10.2	Package thermal characteristics	41
10.2.1	Reference document	41

---

<b>11</b>	<b>Ordering information</b> .....	<b>42</b>
	11.1 STM8T141 ordering information scheme .....	42
	11.2 Orderable favorite device lists .....	43
	11.3 In-factory option byte programming service .....	43
<b>12</b>	<b>STM8T141 development tools</b> .....	<b>45</b>
<b>13</b>	<b>Revision history</b> .....	<b>48</b>

## List of tables

Table 1.	Device summary . . . . .	1
Table 2.	STM8T141 pin descriptions . . . . .	9
Table 3.	Explanation of ECF example 1 . . . . .	13
Table 4.	Explanation of ECF example 2 . . . . .	14
Table 5.	Option bytes . . . . .	18
Table 6.	Option byte description . . . . .	19
Table 7.	Detection thresholds . . . . .	22
Table 8.	Low power period according to selected power mode . . . . .	23
Table 9.	Voltage characteristics . . . . .	30
Table 10.	Current characteristics . . . . .	30
Table 11.	Thermal characteristics . . . . .	30
Table 12.	Operating characteristics . . . . .	30
Table 13.	Average current consumption without shield . . . . .	31
Table 14.	Output pin characteristics . . . . .	32
Table 15.	Regulator and reference voltage . . . . .	32
Table 16.	General capacitive sensing characteristics . . . . .	33
Table 17.	Response times . . . . .	34
Table 18.	External sensing component characteristics . . . . .	34
Table 19.	EMS data . . . . .	35
Table 20.	EMI data . . . . .	36
Table 21.	ESD absolute maximum ratings . . . . .	36
Table 22.	Electrical sensitivities . . . . .	37
Table 23.	8-lead plastic small outline - package mechanical data . . . . .	39
Table 24.	8-lead ultra thin fine pitch dual flat - package mechanical data . . . . .	40
Table 25.	Thermal characteristics . . . . .	41
Table 26.	Orderable favorite device lists . . . . .	43
Table 27.	Ordering information . . . . .	47
Table 28.	Document revision history . . . . .	48

## List of figures

Figure 1.	STM8T141 block diagram	8
Figure 2.	S08 pinout.	9
Figure 3.	UFDFPN8 pinout	9
Figure 4.	Coupling with hand increases the capacitance of the sensing electrode	10
Figure 5.	STM8T measuring circuitry.	11
Figure 6.	Conversion period examples	11
Figure 7.	Environmental compensation filter (ECF) example 1	13
Figure 8.	Environmental compensation filter (ECF) example 2	14
Figure 9.	Reference freeze timeout	15
Figure 10.	Typical application schematic.	17
Figure 11.	Possible load configurations	17
Figure 12.	Active mode output operation.	20
Figure 13.	Toggle mode output operation	21
Figure 14.	3-second latch mode output operation	21
Figure 15.	30-second latch mode output operation	22
Figure 16.	Charge cycle timing diagram in Normal Power mode	23
Figure 17.	Charge cycle timing diagram in Low Power mode with Zoom	24
Figure 18.	Charge cycle timing diagram in Extreme Low Power mode with Zoom	24
Figure 19.	Charge cycle timing diagram in Extreme Low Power mode	25
Figure 20.	Connecting the shield (coaxial cable implementation)	27
Figure 21.	Pin loading conditions.	29
Figure 22.	$I_{DD}$ average current consumption vs $R_{SHIELD}$	31
Figure 23.	Sigma variation across $V_{DD}$	34
Figure 24.	SO8-lead plastic small outline - package outline	38
Figure 25.	UFDFPN8-lead ultra thin fine pitch dual flat package (MLP) package outline	40
Figure 26.	STM8T141 ordering information scheme	42
Figure 27.	STM8T141-EVAL evaluation kit	45
Figure 28.	STM8T141 blank module box.	46
Figure 29.	STM8T141-EVAL programming tool.	47

# 1 Description

The STM8T141 is a ProxSense™ single-channel, fully integrated, charge-transfer, capacitive sensor that is designed to replace conventional electromechanical switches in cost-sensitive applications.

*Note: ProxSense™ is a trademark of Azoteq.*

The STM8T141 is offered in 8-pin packages and is ideally suited for 1-button applications. It can be configured either in touch or proximity sensing mode for wake-up or backlighting on actuation.

The extremely low current consumption makes it an ideal solution for battery-powered applications.

The device features an internal voltage regulator to enhance detection sensitivity and stability.

The STM8T141 touchpad can sense through almost any dielectric and can thereby contain the electronics in a sealed environment.

The STM8T141 also incorporates the advantages of using a driven shielding capability. This makes it possible to separate the sealed electronics from the sensing electrode. The shield feature enables the designer to protect part of the sensing element from unwanted environmental interference and enhances proximity detection when used with battery (DC) applications.

## 2 Block diagram

Figure 1. STM8T141 block diagram

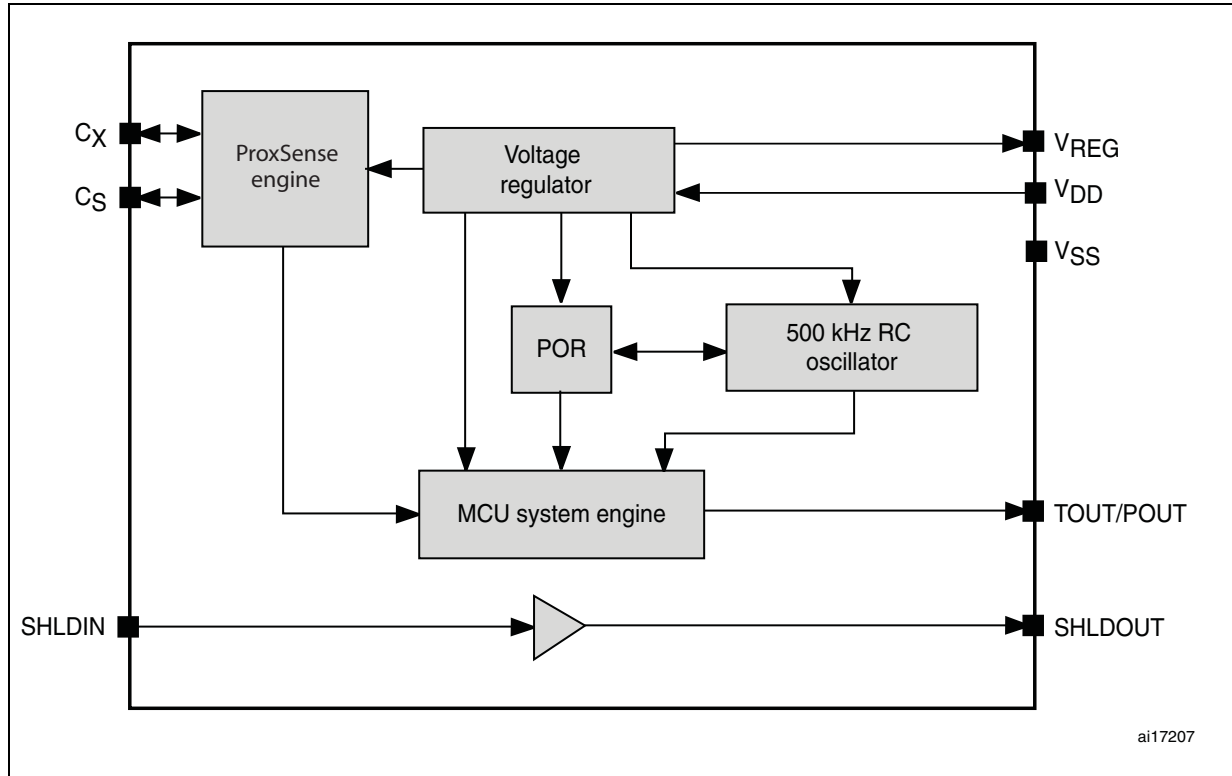

### RC oscillator

The 500-kHz RC oscillator is an internal fixed frequency oscillator used to supply the clock to the MCU system engine.

### Power-On-Reset (POR)

The POR generates a reset signal depending on the power supply level and the clock pulses received from the RC oscillator.

### Voltage regulator

The voltage regulator has an internal comparison and feedback circuit that ensures the  $V_{REG}$  voltage is kept stable and constant. The regulator requires an external smoothing capacitor.

### MCU system engine

The MCU system engine controls the capacitive sensing engine and processes touch and proximity detection signals.

### ProxSense engine

The ProxSense engine circuitry employs a charge-transfer method to detect changes in capacitance.

### 3 Pin descriptions

Figure 2. S08 pinout

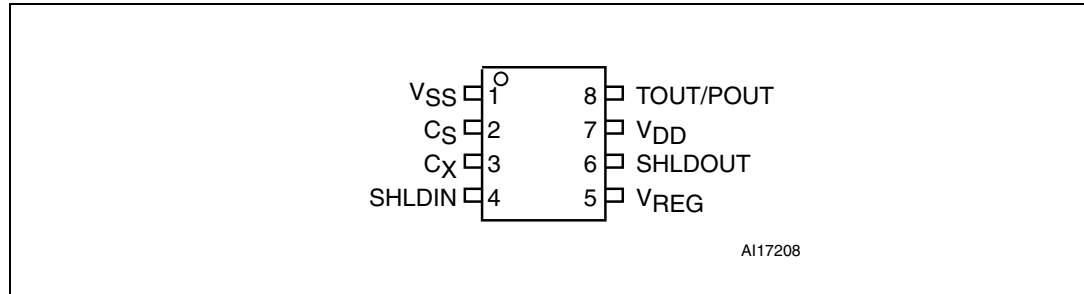

Figure 3. UFDFPN8 pinout

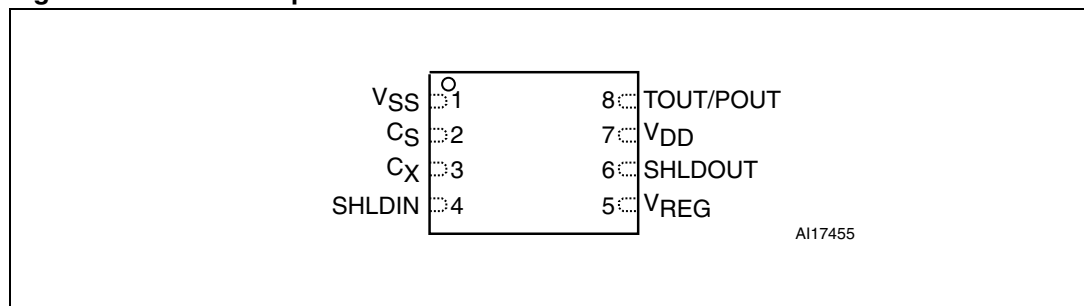

Table 2. STM8T141 pin descriptions

Pin no.		Pin type <sup>(1)</sup>	Pin name	Pin function
S08	UFDFPN8			
1		S	V <sub>SS</sub>	Ground
2		SNS	C <sub>S</sub>	Capacitive sensing channel pin to C <sub>S</sub> <sup>(2)</sup>
3		SNS	C <sub>X</sub>	Capacitive sensing channel pin to R <sub>X</sub>
4		I	SHLDIN <sup>(3)</sup>	Shield input
5		S	V <sub>REG</sub>	Internal voltage regulator output <sup>(4)</sup>
6		OD	SHLDOUT	Shield output
7		S	V <sub>DD</sub>	Supply voltage
8		PP	TOUT/POUT	Touch/proximity <sup>(5)</sup> output (active high)

1. I: input pin, OD: open drain, PP: output push-pull pin, S: supply pin and SNS: capacitive sensing pin.
2. Use COG or NPO capacitor type.
3. If the active shield is unused, please connect this pin to V<sub>SS</sub>.
4. Requires a low ESR, 1µF capacitor to ground. This output must not be used to power other devices.
5. Depending on the value of bits [1:0] of OPT0.

## 4 STM8T ProxSense technology

### 4.1 Capacitive sensing overview

A capacitance exists between any reference point and ground as long as they are electrically isolated. If this reference point is a sensing electrode, it can help to think of it as a capacitor. The positive electrode of the capacitor is the sensing electrode, and the negative electrode is formed by the surrounding area (virtual ground reference in [Figure 4](#)).

**Figure 4. Coupling with hand increases the capacitance of the sensing electrode**

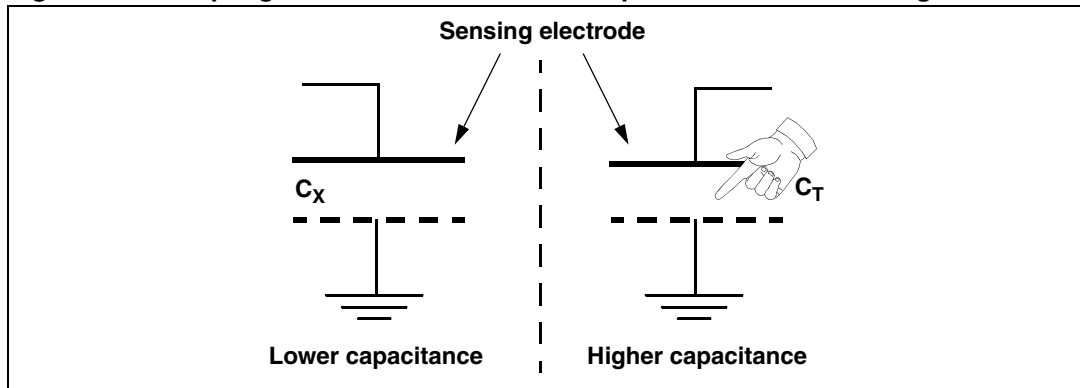

When a conductive object is brought into proximity of the sensing electrode, coupling appears between them, and the capacitance of the sensing electrode relative to ground increases. For example, a human hand raises the capacitance of the sensing electrode as it approaches it. Touching the dielectric panel that protects the electrode increases its capacitance significantly.

### 4.2 Charge transfer acquisition principle

To measure changes in the electrode capacitance, STM8T devices employ bursts of charge-transfer cycles.

The measuring circuitry is connected to the  $C_X$  pin. It is composed of a serial resistor  $R_X$  plus the sensing electrode itself of equivalent capacitance  $C_X$  (see [Figure 5](#)). The sensing electrode can be made of any electrically conductive material, such as copper on PCBs, or transparent conductive material like Indium Tin Oxide (ITO) deposited on glass or Plexiglas. The dielectric panel usually provides a high degree of isolation to prevent ESD discharge from reaching the STM8T touch sensing controller. Connecting the serial resistor ( $R_X$ ) to the  $C_X$  pin improves ESD immunity even more.

**Figure 5. STM8T measuring circuitry**

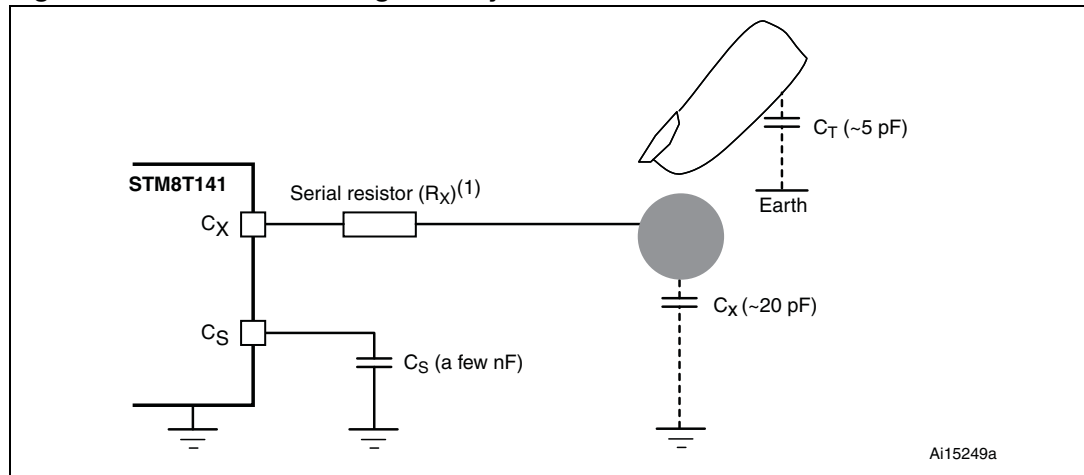

1.  $R_X$  must be placed as close as possible to the STM8T device.

The principle of charge transfer is to charge the electrode capacitance ( $C_X$ ) using a stable power supply. When  $C_X$  is fully charged, part of the accumulated charge is transferred from  $C_X$  to an external sampling capacitance, referred to as  $C_S$ . The transfer cycle is repeated until the voltage across the sampling capacitor  $C_S$  reaches the end of acquisition reference voltage ( $V_{TRIP}$ ). The change in the electrode capacitance is detected by measuring the number of transfer cycles composing a burst (see [Figure 6](#)).

Throughout this document the following naming conventions apply:

- The charge transfer period ( $t_{TRANSFER}$ ) refers to the charging of  $C_X$  and the subsequent transfer of the charge to  $C_S$ .
- The burst cycle duration ( $t_{BURST}$ ) is the time required to charge  $C_S$  to  $V_{TRIP}$ .
- The sampling period ( $t_{SAMPLING}$ ) is the acquisition rate.

**Figure 6. Conversion period examples**

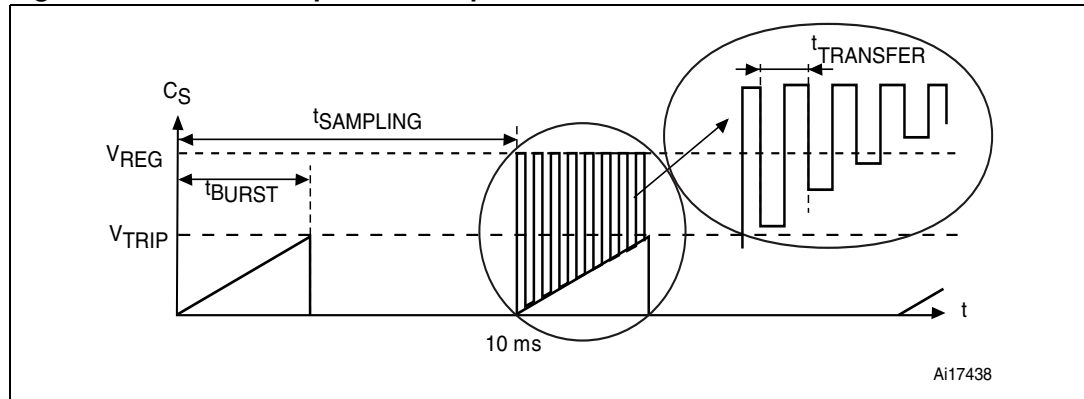

## 5 STM8T processing

The STM8T141 device is designed to ensure reliable operation whatever the environment and operating conditions. To achieve this high level of robustness, dedicated processing have been implemented:

- Signal and reference calculation
- Determining touch/proximity
- Self-calibration
- Environmental compensation filter
- Debounce filter

### 5.1 Signal and reference calculation

Capacitive touch or proximity sensing is a technique based on detecting the electrode capacitance change when someone is in proximity of the sensing electrode. The capacitance change, induced by the presence of a finger or a hand in the device detection area, is sensed by the variation in the number of charge transfer pulses composing the burst. The charge transfer pulse number, also called “signal” is compared to a reference to decide if there is a touch/proximity detection or not.

At power-up, a calibration sequence is performed to compute one reference value per capacitive sensing channel. The reference is extracted from 32 burst measurements. Then, the ECF takes care of its slow evolution over time.

To speed up the calibration process, the device is kept in normal mode whatever the low power mode selected. The device operates in the selected low power mode when the calibration process is completed.

### 5.2 Determining touch/proximity

The minimum difference between the reference and the signal necessary to report a touch/proximity is the detection threshold ( $D_{Th}$ ). A time filtering, similar to the debouncing of the mechanical switches, is applied to avoid noise induced detections.

Four different detection threshold settings are available and selectable by option byte. The touch and sensitive touch levels are relative, which means the actual sensing distance is not influenced by the Cs capacitor. The two thresholds should be able to adapt to various surroundings and panel material or thickness. The proximity sensitivity thresholds are absolute. This implies that the detection distance increases with the Cs capacitor. It provides an easy way to tune the proximity sensing distance according to the application needs.

## 5.3 Environment compensation filter (ECF)

### 5.3.1 ECF principle

The capacitive sensing channel reference value increases or decreases according to environmental conditions such as temperature, power supply, moisture, and surrounding conductive objects. The STM8T141 includes a built-in digital infinite impulse response (IIR) filter capable of tracking slow changes in the environment called the Environment Compensation Filter (ECF). This is a first order digital low pass filter with a gain of one. The filter makes the reference follow slow changes of the signal while fast changes are recognized as a touch or proximity.

When a touch or proximity condition is detected, the corresponding capacitive sensing channel reference is frozen.

Figure 7. Environmental compensation filter (ECF) example 1

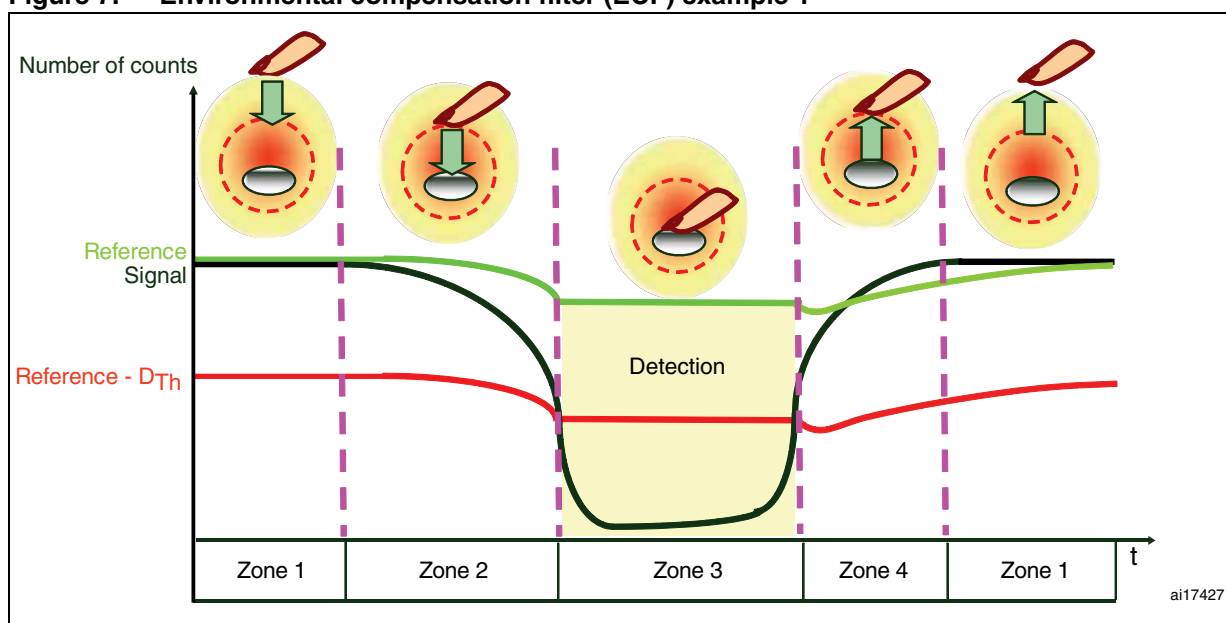

Table 3. Explanation of ECF example 1

	Zone 1	Zone 2	Zone 3	Zone 4
Event description	The object (finger) is outside the electrode field range. Electrode environment is stable	The object, is inside the electrode field range. It induces a signal change but, not large enough to cross the detection threshold ( $D_{Th}$ ). The reference adapts slowly to the object proximity.	The object comes inside the detection range before the reference compensates for its presence. A touch or proximity event is triggered because the signal level falls below the reference - $D_{Th}$ .	The object exits from the electrode's detection range.
Detection state	No detection		Detection	No detection
ECF operation	Active		Halt	Active
Reference	Adapting		Frozen	Adapting

Figure 8. Environmental compensation filter (ECF) example 2

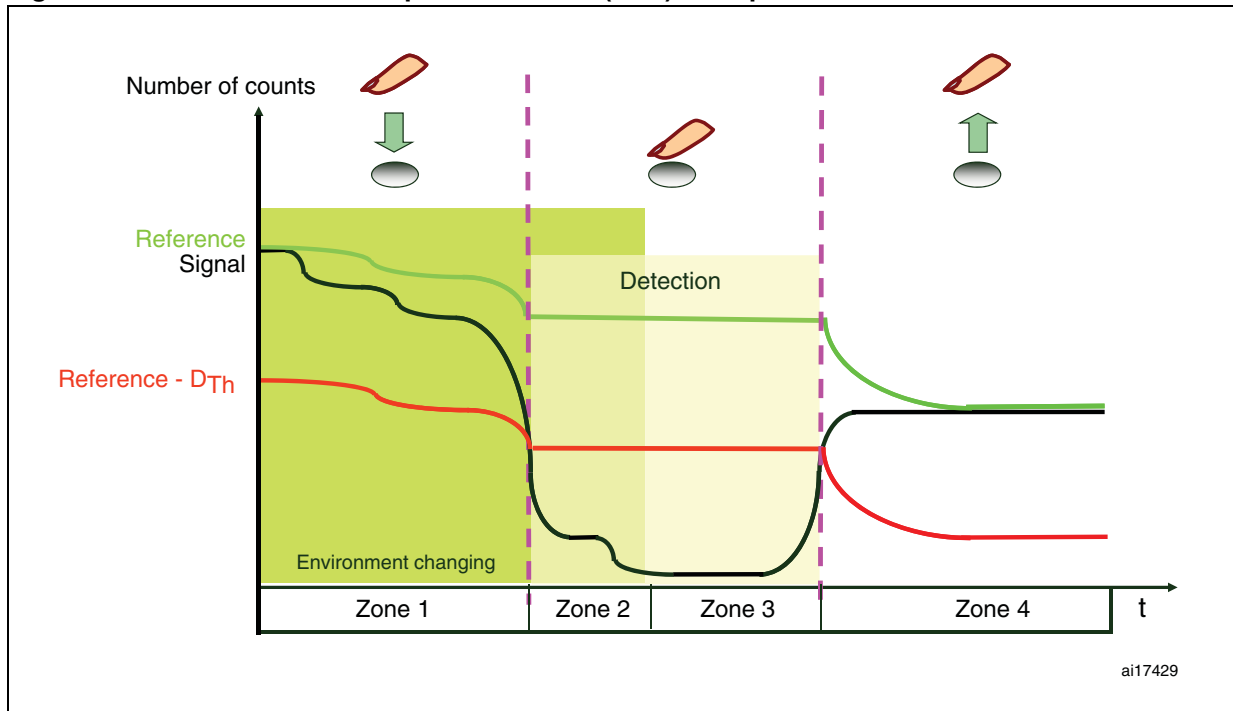

Table 4. Explanation of ECF example 2

	Zone 1	Zone 2	Zone 3	Zone 4
Event description	The system environment changes and the device adapts its reference according to this environment change.	An object (finger) is detected. The environment continues to change.	The object is still under detection but, the environment is not changing anymore.	The object exits from detection.
Detection operation	No detection	Detection		No detection
ECF state	Active	Halt		Active
Reference	Adapting	Frozen		Adapting
Surrounding environment	Changing		Stable	

### 5.3.2 Reference freeze timeout

To prevent an object under detection from influencing the reference value, the ECF is halted as soon as a detection happens. Consequently, the reference is frozen.

In order to be able to recover from a sudden environment change, the reference freeze ends after a maximum programmable delay called the “reference freeze timeout” ( $t_{RFT}$ ).

When a detection lasts longer than the  $t_{RFT}$ , the ECF is enabled again and the reference moves toward the detection signal. After a short period of time, the difference between the signal and the reference become smaller than the detection threshold and the device reports no detection.

*Note: Reference freeze timeout was incorrectly called “recalibration timeout” in previous versions of this document.*

**Figure 9. Reference freeze timeout**

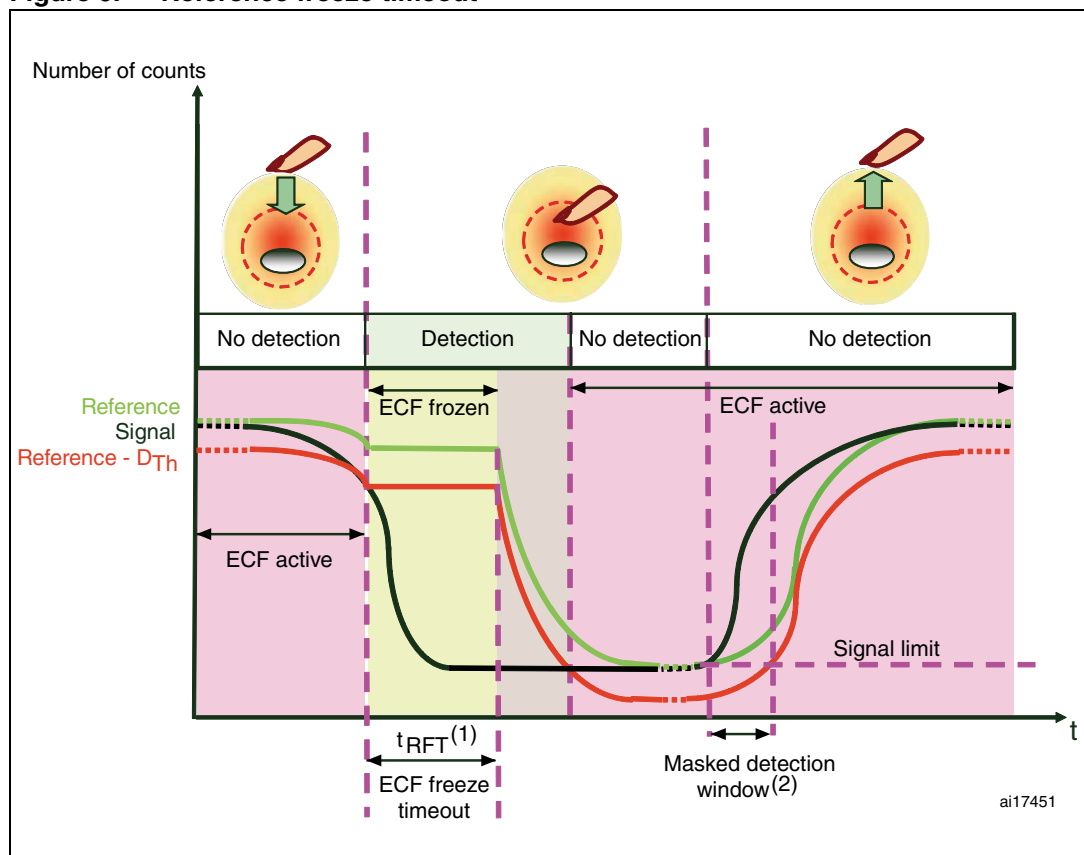

1. See max values of  $t_{RFT}$  in [Table 16: General capacitive sensing characteristics](#).
2. Between the moment when the finger is removed from the sensor and the instant the reference -  $D_{Th}$  curve crosses the signal limit, the device is unable to detect a new touch. This delay is called “masked detection window”. It depends on the environmental change or object signal variation speed inside the electrode’s field. The detection threshold also impacts the masked detection window.

### 5.3.3 Debounce filter

The debounce filter mechanism works together with the ECF to dramatically reduce the effects of noise on the touch and proximity detection. Debouncing is applied to acquisition samples to filter undesired abrupt changes.

The number of consecutive detection debounce count (DDC) and end of detection debounce count (EDDC) needed to identify a proximity/touch detection are defined in [Section 9.5: Capacitive sensing characteristics on page 33](#).

## 6 Typical application diagram

Figure 10. Typical application schematic

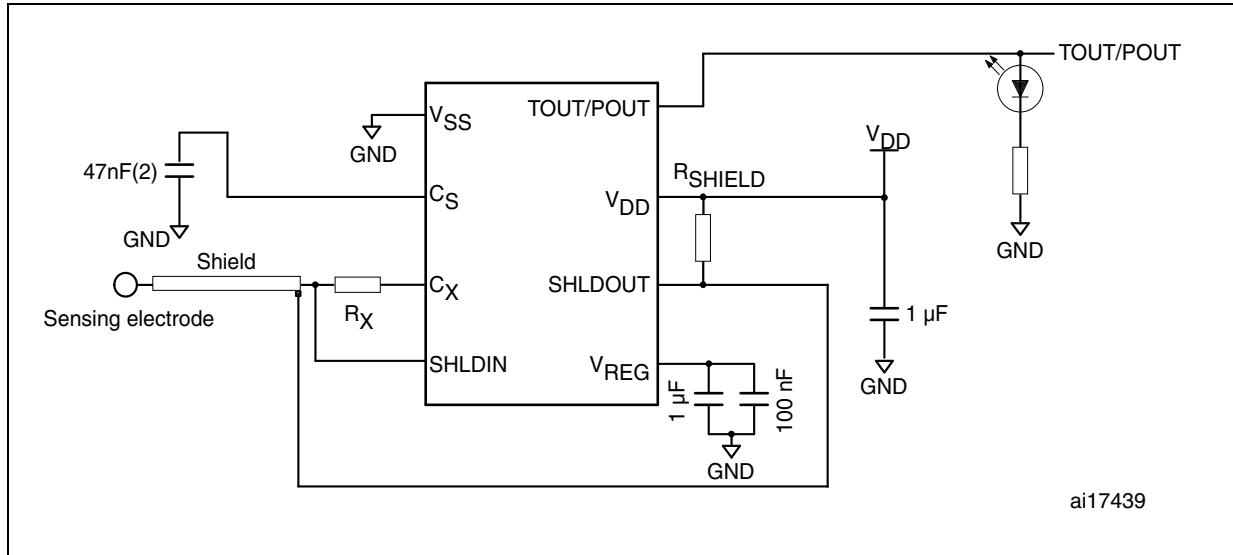

1. If the active shield is not used, The SHLDIN pin must be grounded, SHLDOUT should be left unconnected, and  $R_{SHIELD}$  can be removed.
2. Use COG or NPO or higher grade capacitor.

The smaller the value of the  $R_{SHIELD}$  resistor, the better its effect but, the greater the device consumption.

Pin TOUT/POUT can directly drive a HV FET (as shown in [Figure 11](#)) that, in turn, can drive any load.

Figure 11. Possible load configurations

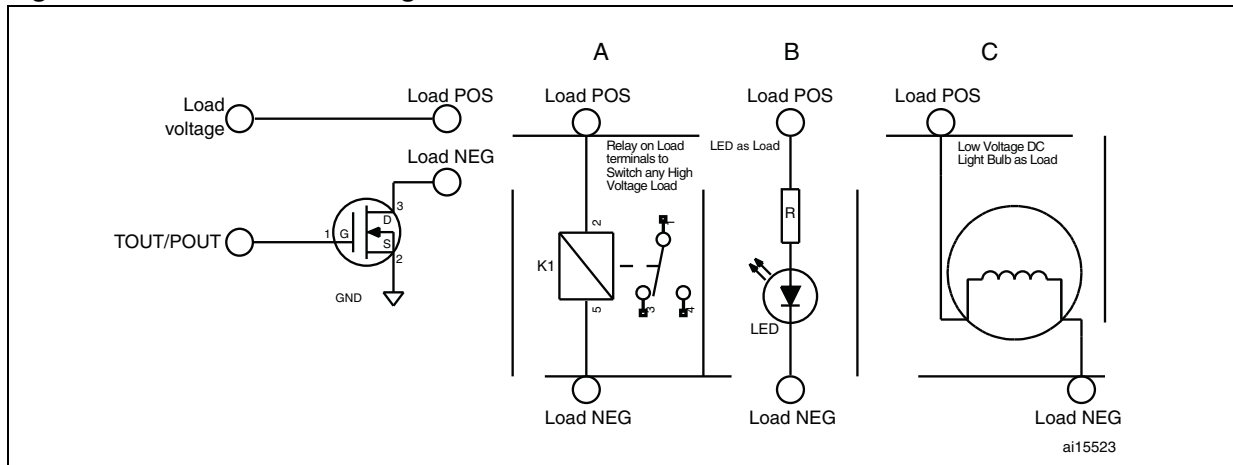

A touch or proximity detection is defined as an actuation (high = logical '1' and low = logical '0').

## 7 Device operation

The STM8T141 can be configured through a set of selectable one-time programmable (OTP) option bytes. These options can be used in their default (unconfigured) state or set for specific applications. For large orders, preconfigured devices are available (please refer to [Section 11: Ordering information](#)).

The STM8T141 can be configured to act as a touch or proximity detection device. A number of other options are also user programmable, including:

- Four output modes
  - Active mode
  - Toggle mode
  - 3-second Latch mode
  - 30-second Latch mode
- TOUT/POUT output mode selection
- Four detection thresholds
  - Two for touch detection
  - Two for proximity detection
- Four power modes
  - Normal power mode
  - Three low power modes
- Reference freeze timeout

### 7.1 Option byte description

A set of tools is supplied by STMicroelectronics to program the user OTP options for prototyping purposes. Please refer to [Section 12: STM8T141 development tools](#) for more details.

*Note:* Devices that are not yet programmed (“blank” devices) are delivered cleared (at value ‘0’) for all bits.

**Table 5. Option bytes**

Option byte no.	Option bits								Factory default setting
	Bit 7	Bit 6	Bit 5	Bit 4	Bit 3	Bit 2	Bit 1	Bit 0	
OPT1	Reserved					Sampling period	Charge transfer frequency	Reserved	0xX0
OPT0	Power mode		Detection threshold		Reference freeze timeout		TOUT/POUT output mode		0x00

The user options allow the STM8T141 to be customized for each specific application. Default values for the oscillator, conversion rate ( $t_{\text{SAMPLING}}$ ), filter freeze and device reset settings should be used initially for first designs.

Table 6. Option byte description

Option byte no.	Description
OPT1	<b>Bits [7:3]: Reserved</b>
	<b>Bit 2: Sampling period (<math>t_{\text{SAMPLING}}</math>)</b> ( <a href="#">Section 7.6: Sampling period</a> ) 0: Conversion period is 20 ms 1: Conversion period is 10 ms
	<b>Bit 1: Charge transfer frequency (<math>f_{\text{TRANSFER}}</math>)</b> ( <a href="#">Section 7.5: Charge transfer frequency</a> ) 0: 125 kHz 1: 250 kHz
	<b>Bit 0: Reserved</b>
OPT0	<b>Bits [7:6]: Power mode</b> ( <a href="#">Section 7.4: Power modes</a> ) 00: Low Power mode with Zoom 01: Normal Power mode 10: Extreme Low Power mode with Zoom 11: Extreme Low Power mode
	<b>Bits [5:4]: Detection threshold</b> ( <a href="#">Section 7.3: Detection threshold</a> ) 00: Standard proximity 01: Standard touch 10: Sensitive proximity 11: Sensitive touch
	<b>Bits [3:2]: Reference freeze timeout</b> ( <a href="#">Section 5.3.2: Reference freeze timeout</a> ) 00: 15-second reference freeze timeout 01: 45-second reference freeze timeout 10: Reserved 11: Infinite reference freeze
	<b>Bits [1:0]: TOUT/POUT output mode</b> ( <a href="#">Section 7.2: TOUT/POUT output mode</a> ) 00: Active mode 01: Toggle mode 10: 3-second Latch mode 11: 30-second Latch mode

## 7.2 TOUT/POUT output mode

Four output modes are available on the STM8T141:

- Active mode
- Toggle mode
- 3-second Latch mode
- 30-second Latch mode

For each output operation described, touch or proximity detection can be used. Upon the detection of either of these actions, the TOUT/POUT pin will latch high, otherwise the TOUT/POUT pin stays low. The detailed working of each user interface is described below.

The TOUT/POUT pin is active high, and can source enough current to directly drive a LED. The pin is sourced from  $V_{DD}$  when active. The TOUT/POUT pin always goes high for a minimum time of  $t_{HIGH}$ . For more information, please refer to [Section 9: Electrical characteristics](#).

Bits [1:0] of option byte OPT0 are used to select the correct output mode.

### 7.2.1 Active

Upon the detection of an actuation, the condition of the TOUT/POUT pin will change to high and stay high for as long as the touch or proximity detection condition occurs. [Figure 12](#) illustrates this output operation.

**Figure 12. Active mode output operation**

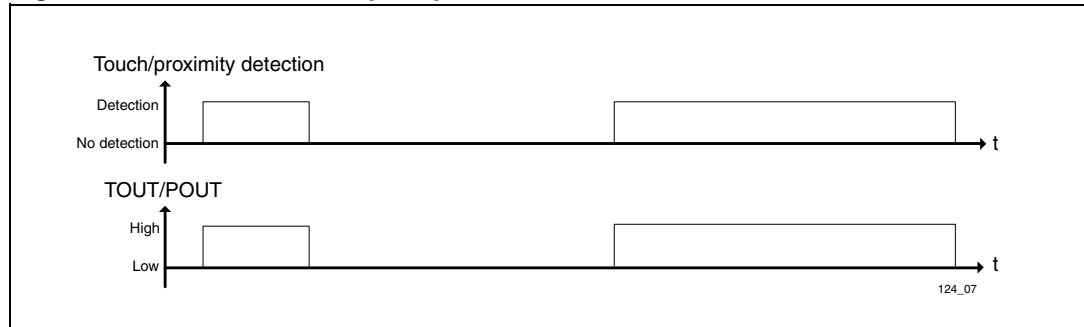

### 7.2.2 Toggle

Upon the detection of an actuation, the TOUT/POUT pin will toggle between high and low. Thus if TOUT/POUT is low, an actuation will change it to high, and also if TOUT/POUT is high, an actuation will change it to low. *Figure 13* illustrates this output operation.

**Figure 13. Toggle mode output operation**

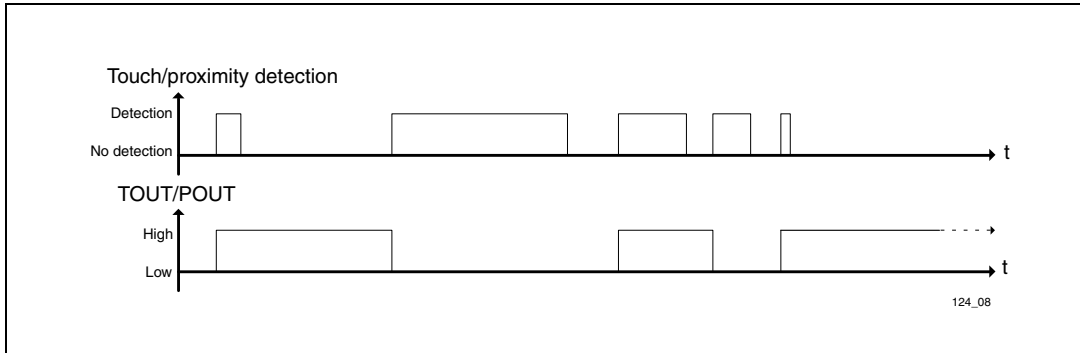

### 7.2.3 3-second latch

Upon the detection of an actuation the TOUT/POUT pin will latch high for 3 seconds minimum. If the actuation occurs for longer than 3 seconds, the TOUT/POUT pin will stay high and will only go low when the actuation stops.

**Figure 14. 3-second latch mode output operation**

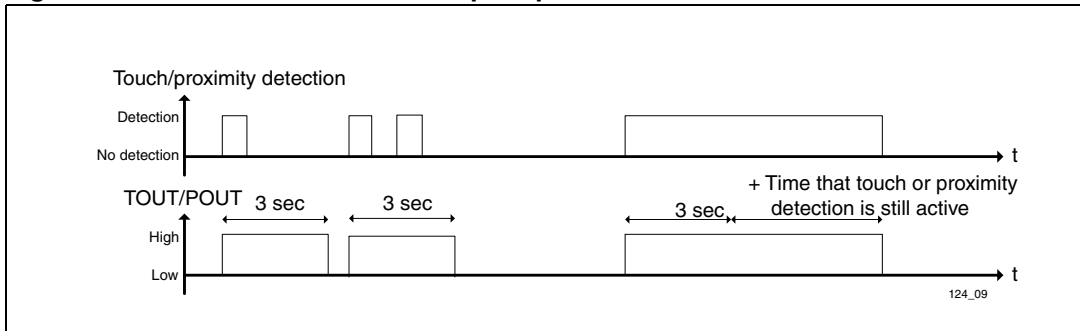

### 7.2.4 30-second latch

Upon the detection of an actuation, the TOUT/POUT pin will latch high. After 30 seconds from when the actuation stops, the TOUT/POUT pin will go low.

If the TOUT/POUT pin is high and another actuation occur before the 30 seconds has expired, the counter will reset and only 30 seconds after the new actuation has stopped, will the TOUT/POUT pin go low. *Figure 15* illustrates this output operation.

**Figure 15. 30-second latch mode output operation**

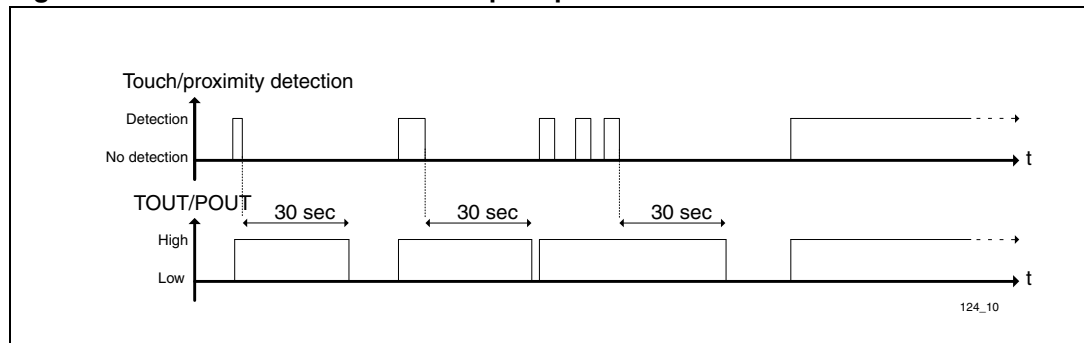

## 7.3 Detection threshold

The user has a choice between four detection threshold levels ( $D_{Th}$ ) at which the touch or proximity detection condition is triggered. This depends on which threshold configuration is selected. See *Table 7* for more details regarding the detection threshold selections.

Bits [5:4] of option byte OPT0 are used to select the correct detection threshold levels.

**Table 7. Detection thresholds**

Sensitivity	$D_{Th}$ setting	Description
Most sensitive 	Sensitive proximity threshold	Proximity for battery-powered applications.
	Standard proximity threshold	Proximity with good ground. Contact through 3 mm acrylic glass and no ground.
	Sensitive touch threshold	Contact through thin acrylic glass with battery application.
Least sensitive	Standard touch threshold	Contact through thin dielectric with good ground.

## 7.4 Power modes

The STM8T141 device offers four power modes. The low power modes are specifically designed for battery applications:

- Normal Power mode
- Low Power mode with Zoom
- Extreme Low Power mode with Zoom
- Extreme Low Power mode

Burst cycles can occur either every 10 ms or 20 ms according to the selected sampling period ( $t_{\text{SAMPLING}}$ ). By selecting low power modes, extra delays are interlaced between bursts. This improves the device current consumption at the expense of the response time.

Bits [7:6] of option byte OPT0 are used to select the correct power mode.

**Table 8. Low power period according to selected power mode**

Power mode	Condition	$t_{\text{LP}}$ value
Normal Power mode		0
Low Power mode with Zoom	Touch or proximity detection	0
	Untouched	$4 \times t_{\text{SAMPLING}}$
Extreme Low Power mode with Zoom	Touch or proximity detection	0
	Untouched	$16 \times t_{\text{SAMPLING}}$
Extreme Low Power mode		$16 \times t_{\text{SAMPLING}}$

### 7.4.1 Normal Power mode

When in Normal Power mode, burst cycles occur at the rate of  $t_{\text{SAMPLING}}$ . No extra delays are added between burst cycles (*Figure 16*).

**Figure 16. Charge cycle timing diagram in Normal Power mode**

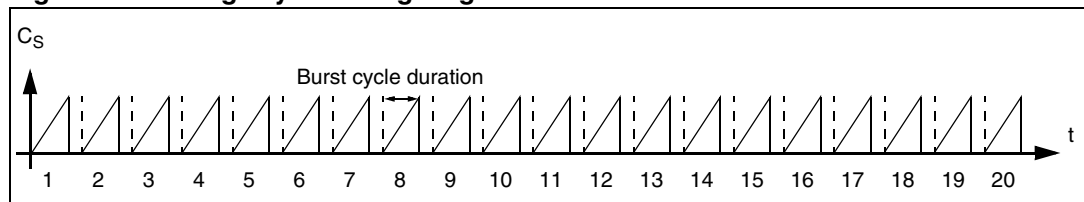

### 7.4.2 Low Power mode with Zoom

With the STM8T141 in Low Power mode with Zoom, burst cycles occur every 5th  $t_{\text{SAMPLING}}$  period (or 20% of the Normal Power mode).

Once activity is detected, the STM8T141 device wakes up from Low Power mode with Zoom to Normal Power mode with charge cycles occurring every  $t_{\text{SAMPLING}}$  period. The device will return to Low Power mode after an end of low power period ( $t_{\text{ELP}}$ ) when no touch or proximity detection conditions are detected. This enables the device to reduce power consumption when not in use, and still have a sufficient response time when needed (Figure 17).

**Figure 17. Charge cycle timing diagram in Low Power mode with Zoom**

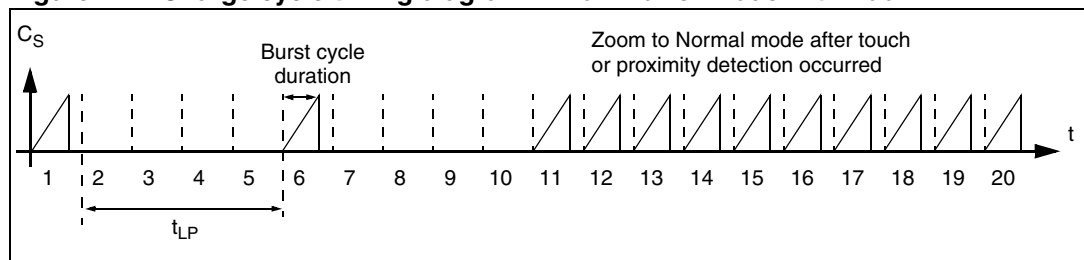

### 7.4.3 Extreme Low Power mode with Zoom

With the STM8T141 in Extreme Low Power Mode with Zoom, burst cycles only occur every 17th  $t_{\text{SAMPLING}}$  period (or 5.88% of the Normal Power mode).

Once activity is detected, the STM8T141 device wakes up from Extreme Low Power mode and Zoom to Normal Power mode with charge cycles occurring every  $t_{\text{SAMPLING}}$ . The device will return to Low Power mode after an end of low power period ( $t_{\text{ELP}}$ ) when no touch or proximity detection conditions are detected. This enables the device to reduce power consumption when not in use and still have a sufficient response time when needed (Figure 18).

**Figure 18. Charge cycle timing diagram in Extreme Low Power mode with Zoom**

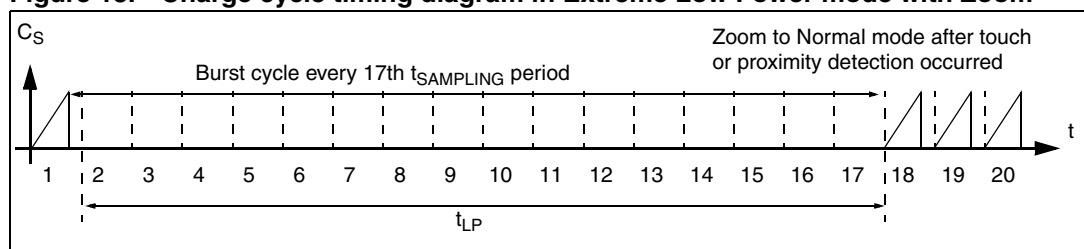

### 7.4.4 Extreme Low Power mode

With the STM8T141 in Extreme Low Power mode, burst cycles only occur every 17th  $t_{\text{SAMPLING}}$  period (or 5.88% of the Normal Power mode), thus adding 16 extra delays of  $t_{\text{SAMPLING}}$  between charge cycles to conserve power.

This reduces the amount of burst cycles in Extreme Low Power mode even more than Low Power mode which in turn saves even more power but comes at the expense of a higher system response time (*Figure 19*).

**Figure 19. Charge cycle timing diagram in Extreme Low Power mode**

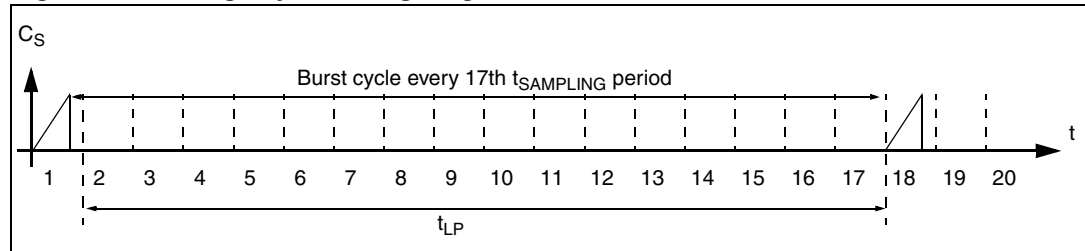

## 7.5 Charge transfer frequency

The STM8T141 offers two charge transfer frequencies. The charge transfer frequency must be adjusted depending on the  $C_S$  capacitor. The charge transfer frequency may need to be raised to 250 kHz in order to reduce  $t_{\text{BURST}}$  when the  $C_S$  capacitance is large.

- 125 kHz
- 250 kHz

Bit 1 of option byte OPT1 is used to select the correct charge transfer frequency.

## 7.6 Sampling period

The default sampling period ( $t_{\text{SAMPLING}}$ ) is configurable in order to allow different compromises between power consumption and conversion rates:

- 20-ms sampling rate to reduce average power consumption
- 10-ms sampling rate to increase detection response time

When using a faster sampling rate ( $t_{\text{SAMPLING}} = 10 \text{ ms}$ ), all the timing values of the Power modes will occur at twice the speed.

Bit 2 of option byte OPT1 is used to select the correct conversion period.

## 8 Design guidelines

### 8.1 Shield function

The STM8T141 offers a built-in shielding function. This function provides the following advantages for designing the end-application:

- Sensing electrode separated from sealed electronics.
- Sensing wire shielded from unwanted environmental interferences.
- Enhanced proximity detection when used with battery (DC) applications.

The shield principle consists in actively driving the shield plane or element with the same signal as that of the electrode. The parasitic capacitance between the electrode and the shield does not need to be charged anymore and its effect on the sensitivity is cancelled.

*Note:* *Grounding the shield reduces the sensitivity of the keys and may render the system unusable.*

#### 8.1.1 Shield application example

Ideally, a coaxial cable is used for the shield. A  $R_X$  (typically 2 k $\Omega$ ) resistor should be connected to the  $C_X$  pin. The other side of the  $R_X$  resistor should be connected to the center core of the coaxial cable. The SHLDOUT pin should be connected to the metallic shield part of the coaxial cable. A pull-up resistor ( $R_{SHIELD}$ ) should be added between SHLDOUT and  $V_{DD}$  as shown in [Figure 20](#).

The example shown in [Figure 20](#) is given for  $R_X = 2$  k $\Omega$ ,  $R_{SHIELD} = 100$  k $\Omega$ , and  $V_{DD} = 5$  V<sup>(a)</sup>. This setup has been successfully implemented with a coaxial cable of up to 4 m.

A longer coaxial cable could be used, but this would mean decreasing the  $R_{SHIELD}$  resistor, and consequently increasing current consumption.

*Note:* *A smaller  $R_{SHIELD}$  ensures better shielding but increases current consumption (see [Figure 20](#)).*

---

a.  $V_{DD}$  must range from 4.5 to 5.5 V to use the shield function. Please refer to [Table 12: Operating characteristics](#) for the correct power supply operating voltage when using the shield function.

Figure 20. Connecting the shield (coaxial cable implementation)

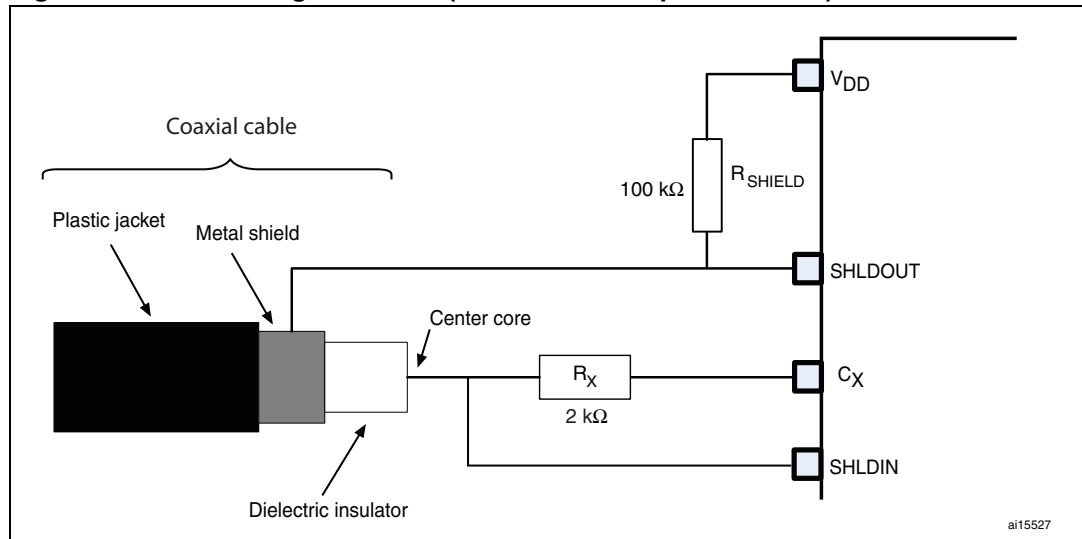

## 8.2 Sensitivity adjustment

Several factors impact device sensitivity:

- The sensing electrode material and size
- The touch panel material and thickness
- The board layout and in particular the sensing signal tracks
- The value of the sampling capacitor ( $C_S$ ) for proximity thresholds only
- The ground coupling of the object (finger or hand) and sensor.
- The touch or proximity detection threshold selected by the option byte.

### 8.2.1 $C_S$ influence on sensitivity

In touch mode, the  $C_S$  capacitor value has no influence on the sensitivity as the thresholds are relative to the actual reference value. In proximity mode, the  $C_S$  value allows the sensitivity to be tuned. A higher sampling capacitor value increases the resolution and the sensitivity but also the charging time. Decreasing the sampling capacitor value therefore decreases the sensitivity.

For more details, please refer to application note *AN2966*.

### 8.2.2 PCB layout and construction

The PCB traces, wiring, and components associated or in contact with  $C_X$  pins become touch sensitive and should be treated with caution to limit the touch area to the desired location. As an example, multiple touch electrodes connected to a sensing channel can be used to create control surfaces on both sides of an object.

It is important to limit the amount of stray capacitance on the  $C_X$  pin. This can be done by minimizing trace lengths and widths to achieve for higher gain without using higher values of  $C_S$ . To minimize cross-coupling, electrode traces from adjacent sensing channel should not run close to each other for long distances. For detailed information on the impacts of the first three factors, refer to application note *AN2869*.

### 8.3 Influence of power supply variation

The stability of the device power supply is critical in order to provide a precise and repeatable capacitance measure. For this reason, a linear regulator is embedded into the device to provide the best power supply noise rejection possible.

Even with the embedded regulator, variations of the power supply voltage may have an impact on the measured signal, especially in proximity configurations with a large acquisition gain and small detection threshold.

A variation of the power supply voltage ( $\Delta V$ ) induces a variation of the signal burst count ( $\Delta BC$ ) according to [Equation 1](#).

#### Equation 1

$$\Delta BC = G \times \sigma \times \Delta V$$

The gain,  $G$ , of the acquisition is the ratio  $C_s/C_x$ .

The parameter  $\sigma$  is the power supply rejection ratio.

For stability reasons, it is advised to limit  $\Delta BC$  to less than half the detection threshold. If  $V_{DD}$  is less than 2.9 V, special care should be taken of the supply quality. An external voltage regulator may be necessary.

## 9 Electrical characteristics

### 9.1 Parameter conditions

Unless otherwise specified, all voltages are in reference to  $V_{SS}$ .

#### 9.1.1 Minimum and maximum values

Unless otherwise specified, the minimum and maximum values are guaranteed in the worst conditions of ambient temperature and supply voltage by tests in production on 100% of the devices with an ambient temperature at  $T_A = 25\text{ °C}$  and  $T_A = T_{Amax}$  (given by the selected temperature range).

Data based on characterization results, design simulation and/or technology characteristics are indicated in the table footnotes and are not tested in production. Based on characterization, the minimum and maximum values refer to sample tests and represent the mean value plus or minus three times the standard deviation (mean  $\pm 3\sigma$ ).

#### 9.1.2 Typical values

Unless otherwise specified, typical data are based on  $T_A = 25\text{ °C}$ , and  $V_{DD} = 5\text{ V}$ . They are given only as design guidelines and are not tested.

#### 9.1.3 Typical curves

Unless otherwise specified, all typical curves are given only as design guidelines and are not tested.

#### 9.1.4 Loading capacitor

The loading conditions used for pin parameter measurement are shown in [Figure 21](#).

**Figure 21. Pin loading conditions**

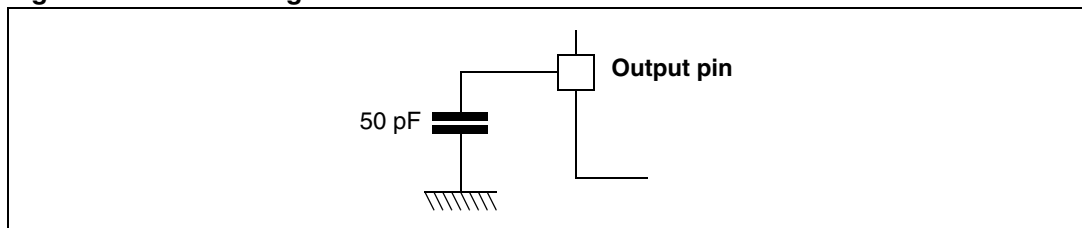

## 9.2 Absolute maximum ratings

Stresses above those listed as “absolute maximum ratings” may cause permanent damage to the device. This is a stress rating only and functional operation of the device under these conditions is not implied. Exposure to maximum rating conditions for extended periods may affect device reliability.

**Table 9. Voltage characteristics**

Symbol	Ratings	Maximum value	Unit
$V_{DD} - V_{SS}$	Supply voltage	5.5	V

**Table 10. Current characteristics**

Symbol	Ratings	Maximum value	Unit
$I_{VDD}$	Total current into $V_{DD}$ power lines (source) <sup>(1)</sup>	11	mA
$I_{VSS}$	Total current out of $V_{SS}$ ground lines (sink) <sup>(1)</sup>	11	
$I_{IO}$	Output current sunk by output pin	10	
	Output current sourced by output pin	10	

1. All power ( $V_{DD}$ ) and ground ( $V_{SS}$ ) lines must always be connected to the external supply.

**Table 11. Thermal characteristics**

Symbol	Ratings	Value	Unit
$T_{STG}$	Storage temperature range	-65 to +150	°C
$T_J$	Junction temperature range (SO8 narrow and UFDFPN8 packages)	90	°C

## 9.3 Operating conditions

### 9.3.1 General operating conditions and supply characteristics

**Table 12. Operating characteristics**

Symbol	Parameter	Condition	Min.	Max.	Unit
$V_{DD}$	Supply voltage	Shield feature not used	2.0	5.5	V
		Shield feature used	4.5	5.5	
$T_A$	Operating temperature	-	-40	85	°C
$t_{VDD}$	Turn-on slope (Rise time rate)		0	1	V/s
	Turn-off slope (Fall time rate)		1 <sup>(1)</sup>	∞	

1. This constraint must be respected only if the voltage does not reach 0 V.

### 9.3.2 Average current consumption

Test conditions:  $T_A = 25\text{ }^\circ\text{C}$ ,  $C_X = 20\text{ pF}$ ,  $C_S = 47\text{ nF}$  and  $R_X = 2\text{ k}\Omega$ .

**Table 13. Average current consumption without shield**

Symbol	Parameter	Conditions	Typ.	Max.	Unit
$I_{DD}$	Normal Power mode	– Shield output unconnected – Shield input grounded – Options other than Low Power are left in default configuration	30	45 <sup>(1)</sup>	$\mu\text{A}$
	Low Power		17		
	Extreme Low Power mode		11		

1. Data based on characterization results, not tested in production.

*Note:* Consumption does not depend on either detection threshold or acquisition rate.

**Figure 22.  $I_{DD}$  average current consumption vs  $R_{SHIELD}$**

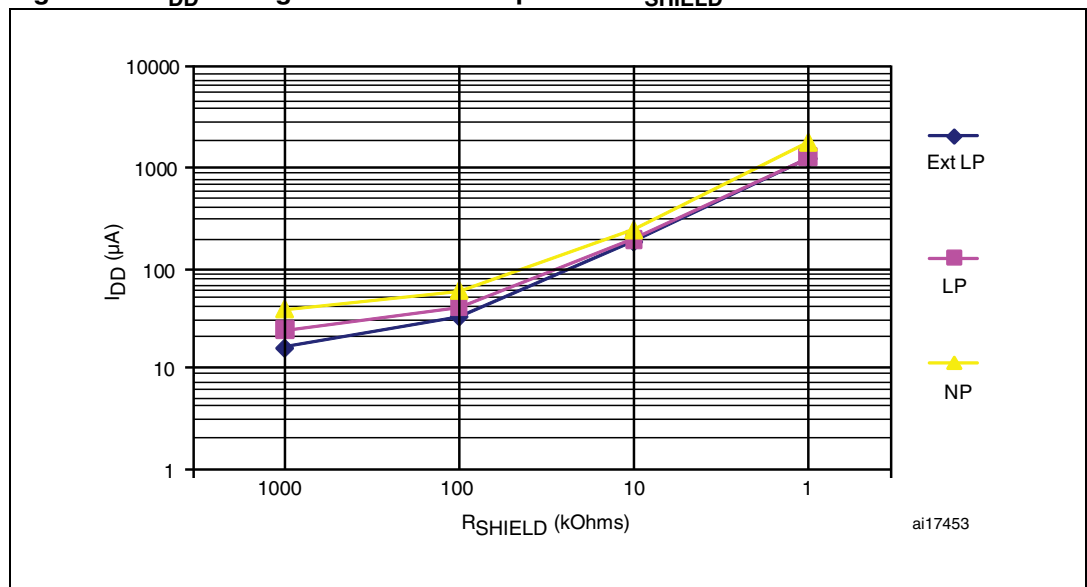

1. ExtLP = External Low Power mode
2. LP = Low Power mode
3. NP = Normal Power mode

### 9.3.3 Output characteristics

Table 14. Output pin characteristics

Symbol	Parameter	Conditions	Typ.	Max.	Unit
V <sub>OL</sub>	V <sub>DD</sub> = 5 V	I <sub>LOAD</sub> = 8 mA	1200	1600	mV
		I <sub>LOAD</sub> = 4 mA	540	750	
		I <sub>LOAD</sub> = 2 mA	250	450	
	V <sub>DD</sub> = 3.3 V	I <sub>LOAD</sub> = 4 mA	650	1000	
		I <sub>LOAD</sub> = 2 mA	320	500	
	V <sub>DD</sub> = 2.0 V	I <sub>LOAD</sub> = 1 mA	300	500	
V <sub>OH</sub>	V <sub>DD</sub> = 5 V	I <sub>LOAD</sub> = -2 mA	4.7		V
		I <sub>LOAD</sub> = -4 mA	4.4		
		I <sub>LOAD</sub> = -8 mA	3.9		
	V <sub>DD</sub> = 3.3 V	I <sub>LOAD</sub> = -2 mA	3.0		
		I <sub>LOAD</sub> = -4 mA	2.7		
	V <sub>DD</sub> = 2.9 V	I <sub>LOAD</sub> = -2 mA	2.5		
	V <sub>DD</sub> = 2.0 V	I <sub>LOAD</sub> = -100 μA	1.8		
	t <sub>HIGH</sub>	Output minimum high time		40	
t <sub>LOW</sub>	Output minimum low time		40		

### 9.4 Regulator and reference voltage

Table 15. Regulator and reference voltage

Symbol	Parameter	Min.	Typ.	Max.	Unit
C <sub>ref</sub>	Voltage regulator decoupling capacitance <sup>(1)</sup>	1		10	μF
V <sub>reg</sub>	Regulated voltage during acquisition		2.1		V
V <sub>trip</sub>	End of acquisition reference voltage		0.68		

1. Equivalent serial R<sub>resistor</sub> ≤ 0.2 Ω at 1 MHz.

## 9.5 Capacitive sensing characteristics

**Table 16. General capacitive sensing characteristics<sup>(1)</sup>**

Symbol	Parameter	Min.	Typ.	Max.	Unit
$t_{\text{TRANSFER}}$	Charge-transfer frequency at 125-kHz setting	90	125	160	kHz
	Charge-transfer frequency at 250-kHz setting	185	250	315	
$t_{\text{SAMPLING}}$	Scanning period at 10-ms setting	7.5	10	12.5	ms
	Scanning period at 20-ms setting	15	20	25	
$t_{\text{LP}}$	Low Power		$4 t_{\text{SAMPLING}}$		
	Extreme Low Power		$16 t_{\text{SAMPLING}}$		
$t_{\text{ELP}}$	Time before switching back to Low Power mode		540		
$t_{\text{RFT}}^{(2)}$	15 s reference freeze timeout	11	15	19	s
	45 s reference freeze timeout	33	45	57	
$t_{\text{BURST}}$	Burst detection	32		$2^{14}$	$t_{\text{TRANSFER}}$
DDC	Detection debounce count		4		Counts
EDDC	End of detection debounce count		3		
$D_{\text{Th}}^{(3)}$	Proximity detection threshold		- 8		Counts
	Sensitive proximity detection threshold		- 2		
	Touch detection threshold		Ref./16		
	Sensitive touch detection threshold		Ref./32		
$\sigma^{(4)}$	Power supply rejection ratio $V_{\text{DDMIN}} < V_{\text{DD}} < 3 \text{ V}$		0.0250		Count/V
	Power supply rejection ratio ( $3.5 \text{ V} < V_{\text{DD}} < V_{\text{DDMAX}}$ )		0.0005		

1. Values guaranteed by design.
2. See  $t_{\text{RFT}}$  in [Figure 9: Reference freeze timeout](#).
3. Reference value (Ref.) described in [Section 5.3.3: Debounce filter on page 16](#).
4. Between 3 V and 3.5 V,  $\sigma$  evolves as shown in [Figure 23](#).

Figure 23. Sigma variation across V<sub>DD</sub>

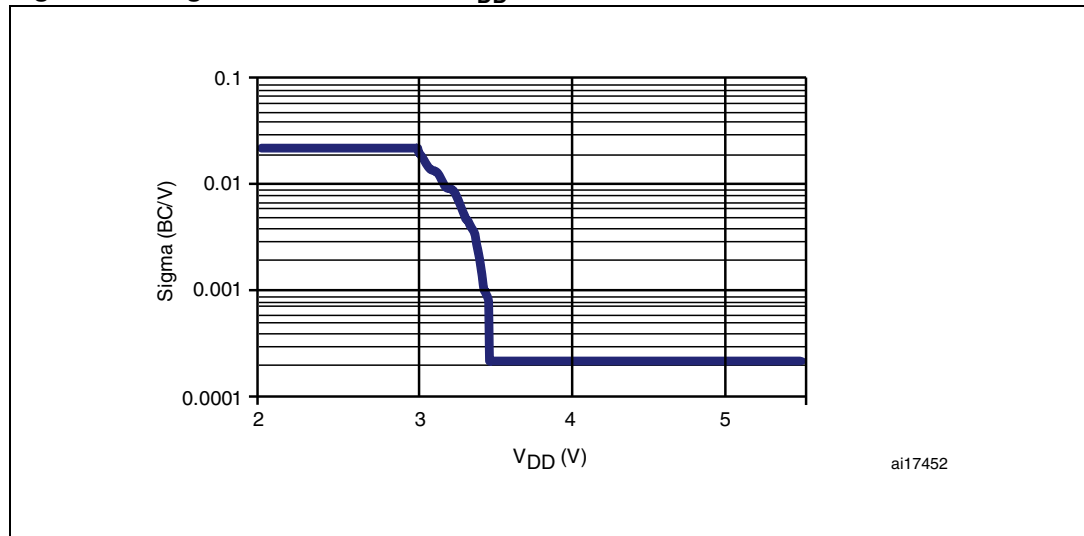

Table 17. Response times <sup>(1)</sup>

Mode	t <sub>SAMPLING</sub> = 10 ms		t <sub>SAMPLING</sub> = 20 ms		Unit
	Min.	Max.	Min.	Max.	
Normal Power mode	30	50	60	100	ms
Low Power with Zoom mode	30	100	60	200	
Extreme Low Power with Zoom mode	30	250	60	500	
Extreme Low Power mode	510	850	1020	1700	

1. Values guaranteed by design.

Table 18. External sensing component characteristics

Symbol	Parameter	Min.	Typ.	Max.	Unit
C <sub>S</sub>	Sampling capacitor (COG or NPO type) <sup>(1)</sup>		47	2 <sup>14</sup> x C <sub>X</sub>	nF
C <sub>X</sub>	Equivalent electrode capacitance			100	pF
C <sub>T</sub>	Equivalent touch capacitance		5		
R <sub>X</sub>	Electrode serial resistance		2	22	kOhm
R <sub>SHIELD</sub>	Shield pull-up resistance	1		1000	

1. For more information about capacitors, please refer to Application note: AN2966.

## 9.6 EMC characteristics

Susceptibility and emission tests are performed on a sample basis during product characterization.

Both the sample and its applicative hardware environment (*Figure 10*) are mounted on a dedicated specific EMC board defined in the IEC61967-1 standard.

### 9.6.1 Functional EMS (electromagnetic susceptibility)

While running in the above described environment the product is stressed by two electromagnetic events until a failure occurs.

- **ESD:** Electrostatic discharge (positive and negative) is applied on all pins of the device until a functional disturbance occurs. This test complies with the IEC 1000-4-2 standard.
- **FTB:** A burst of fast transient voltage (positive and negative) is applied to  $V_{DD}$  and  $V_{SS}$  through a 100 pF capacitor, until a functional disturbance occurs. This test complies with the IEC 1000-4-4 standard.

A device reset allows normal operations to be resumed. The test results are given in *Table 19* based on the EMS levels and classes defined in application note AN1709.

### 9.6.2 Prequalification trials

**Table 19. EMS data**

Symbol	Parameter	Conditions	Level/class
$V_{FESD}$	Voltage limits to be applied on any pin to induce a functional disturbance	$V_{DD} = 5\text{ V}$ , $T_A = +25\text{ °C}$ , SO8 (Narrow) package, complies with IEC 1000-4-2	1B
$V_{EFTB}$	Fast transient voltage burst limits to be applied through 100pF on $V_{DD}$ and $V_{SS}$ pins to induce a functional disturbance	$V_{DD} = 5\text{ V}$ , $T_A = +25\text{ °C}$ , SO8 (Narrow) package, complies with IEC 1000-4-4	4A

### 9.6.3 Electromagnetic interference (EMI)

Emission tests conform to the IEC61967-2 standard for board layout and pin loading. Worse case EMI measurements are performed during maximum device activity.

**Table 20. EMI data**

Symbol	Parameter	General conditions	Monitored frequency band	RC <sub>osc</sub> = 500 kHz <sup>(1)</sup>	Unit	
S <sub>EMI</sub>	Peak level	V <sub>DD</sub> = 5 V, T <sub>A</sub> = +25 °C, SO8 (Narrow) package, Complies with SAE J1752/3, No finger on touch electrode	0.1 MHz to 30 MHz	-4	dBμV	
			30 MHz to 130 MHz	-9		
			130 MHz to 1 GHz	-6		
	SAE EMI level			-1		
	Peak level		V <sub>DD</sub> = 5 V, T <sub>A</sub> = +25 °C, SO8 (Narrow) package, Complies with SAE J1752/3, Finger on touch electrode	0.1 MHz to 30 MHz	20	dBμV
				30 MHz to 130 MHz	-8	
130 MHz to 1 GHz		-7				
SAE EMI level		15				

1. Data based on characterization results, not tested in production.

### 9.6.4 Absolute maximum ratings (electrical sensitivity)

Based on two different tests (ESD and LU) using specific measurement methods, the product is stressed in order to determine its performance in terms of electrical sensitivity. For more details, refer to the application note AN1181.

### 9.6.5 Electrostatic discharge (ESD)

Electrostatic discharges (3 positive then 3 negative pulses separated by 1 second) are applied to the pins of each sample according to each pin combination. The sample size depends on the number of supply pins in the device (3 parts\*(n+1) supply pin). This test conforms to the JESD22-A114A/A115A standard. For more details, refer to the application note AN1181.

**Table 21. ESD absolute maximum ratings**

Symbol	Ratings	Conditions	Class	Maximum value <sup>(1)</sup>	Unit
V <sub>ESD(HBM)</sub>	Electrostatic discharge voltage (Human body model)	T <sub>A</sub> = +25°C, conforming to JESD22-A114	A	2000	V
V <sub>ESD(CDM)</sub>	Electrostatic discharge voltage (Charge device model)	T <sub>A</sub> = +25°C, conforming to JESD22-C101	IV	1000	V

1. Data based on characterization results, not tested in production

### 9.6.6 Static latchup

Two complementary static tests are required on 10 parts to assess the latchup performance.

- A supply overvoltage (applied to each power supply pin) and
- A current injection (applied to each input, output and configurable I/O pin) are performed on each sample.

This test conforms to the EIA/JESD 78 IC latchup standard. For more details, refer to application note AN1181.

**Table 22. Electrical sensitivities**

Symbol	Parameter	Conditions	Class <sup>(1)</sup>
LU	Static latchup class	$T_A = +25\text{ °C}$	A
		$T_A = +85\text{ °C}$	A

1. Class description: A Class is an STMicroelectronics internal specification. All its limits are higher than the JEDEC specifications, that means when a device belongs to class A it exceeds the JEDEC standard. B class strictly covers all the JEDEC criteria (international standard).

# 10 Package characteristics

In order to meet environmental requirements, ST offers these devices in different grades of ECOPACK® packages, depending on their level of environmental compliance. ECOPACK® specifications, grade definitions and product status are available at [www.st.com](http://www.st.com).

ECOPACK® is an ST trademark.

## 10.1 Package mechanical data

### 10.1.1 SO8 package mechanical data

Figure 24. SO8-lead plastic small outline - package outline

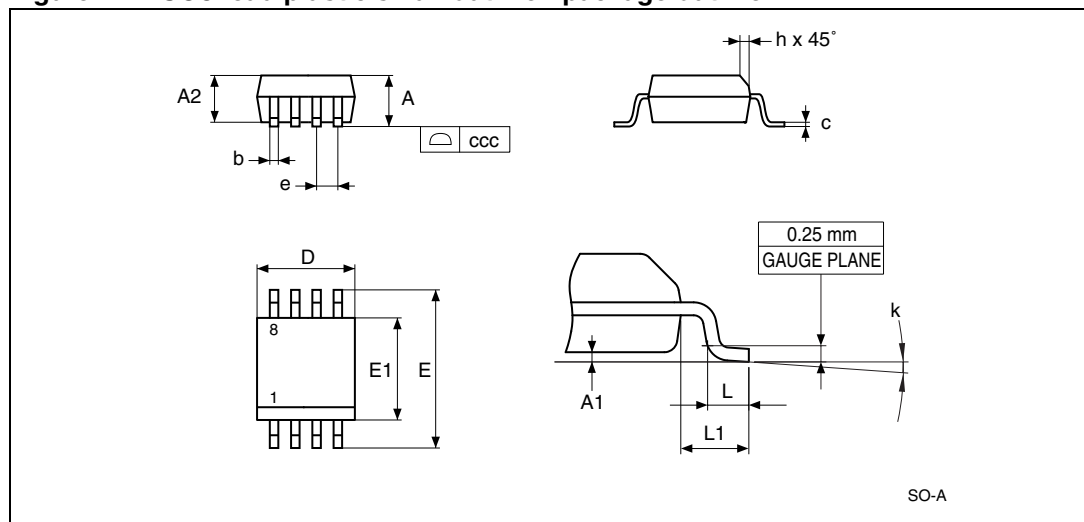

Table 23. 8-lead plastic small outline - package mechanical data

Symbol	millimeters			inches <sup>(1)</sup>		
	Min.	Typ.	Max.	Min.	Typ.	Max.
<b>A</b>	-	-	1.750	-	-	0.0689
<b>A1</b>	0.100	-	0.250	0.0039	-	0.0098
<b>A2</b>	1.250	-	-	0.0492	-	-
<b>b</b>	0.280	-	0.480	0.0110	-	0.0189
<b>c</b>	0.170	-	0.230	0.0067	-	0.0091
<b>ccc</b>	-	-	0.100	-	-	0.0039
<b>D</b> <sup>(2)</sup>	4.800	4.900	5.000	0.1890	0.1929	0.1969
<b>E</b>	5.800	6.000	6.200	0.2283	0.2362	0.2441
<b>E1</b> <sup>(3)</sup>	3.800	3.900	4.000	0.1496	0.1535	0.1575
<b>e</b>	-	1.270	-	-	0.0500	-
<b>h</b>	0.250	-	0.500	0.0098	-	0.0197
<b>k</b>	0°	-	8°	0°	-	8°
<b>L</b>	0.400	-	1.270	0.0157	-	0.0500
<b>L1</b>	-	1.040	-	-	0.0409	-

1. Values in inches are rounded to 4 decimal digits
2. Dimension D does not include mold flash, protrusions or gate burrs. Mold flash, protrusions or gate burrs shall not exceed 0.15mm in total (both side).
3. Dimension E1 does not include interlead flash or protrusions. Interlead flash or protrusions shall not exceed 0.25 mm per side.

10.1.2 UFDFPN8 package mechanical data

Figure 25. UFDFPN8-lead ultra thin fine pitch dual flat package (MLP) package outline

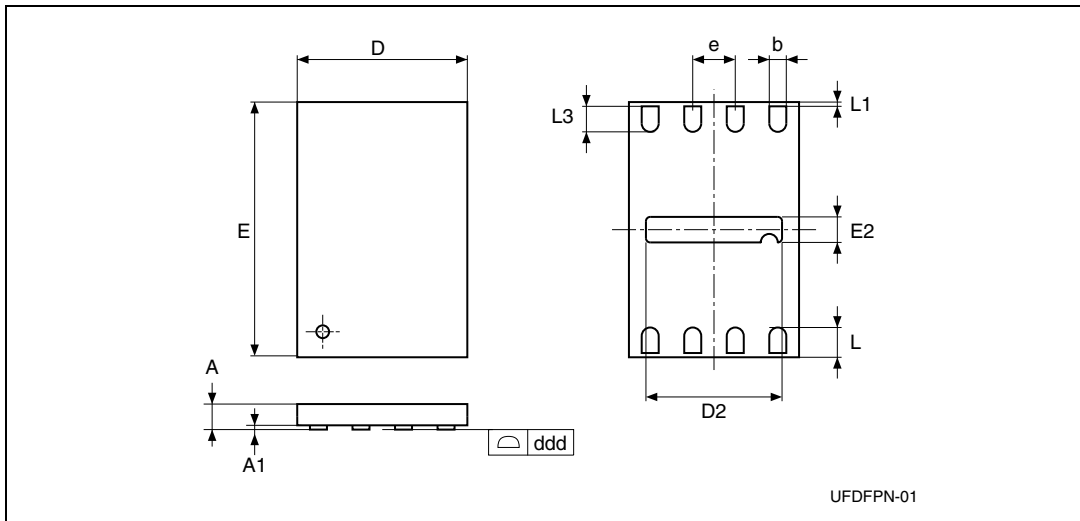

Table 24. 8-lead ultra thin fine pitch dual flat - package mechanical data

Symbol	millimeters			inches <sup>(1)</sup>		
	Min	Typ	Max	Min	Typ	Max
A	0.450	0.550	0.600	0.0177	0.0217	0.0236
A1	0.000	0.020	0.050	0.0000	0.0008	0.0020
b	0.200	0.250	0.300	0.0079	0.0098	0.0118
D	1.900	2.000	2.100	0.0748	0.0787	0.0827
D2	1.500	1.600	1.700	0.0591	0.0630	0.0669
E	2.900	3.000	3.100	0.1142	0.1181	0.1220
E2	0.100	0.200	0.300	0.0039	0.0079	0.0118
e	-	0.500	-	-	0.0197	-
L	0.400	0.450	0.500	0.0157	0.0177	0.0197
L1	-	-	0.150	-	-	0.0059
L3	0.300	-	-	0.0118	-	-
<b>Tolerance</b>	millimeters			inches		
ddd <sup>(2)</sup>	-	0.080	-	-	0.0031	-

1. Values in inches are rounded to 4 decimal digits
2. Applied for exposed die paddle and terminals. Exclude embedding part of exposed die paddle from measuring.

## 10.2 Package thermal characteristics

The maximum chip junction temperature ( $T_{Jmax}$ ) must never exceed the values given in [Table 12: Operating characteristics on page 30](#).

The maximum chip-junction temperature,  $T_{Jmax}$ , in degrees Celsius, may be calculated using the following equation:

$$T_{Jmax} = T_{Amax} + (P_{Dmax} \times \Theta_{JA})$$

Where:

- $T_{Amax}$  is the maximum ambient temperature in °C
- $\Theta_{JA}$  is the package junction-to-ambient thermal resistance in °C/W
- $P_{Dmax}$  is the sum of  $P_{INTmax}$  and  $P_{I/Omax}$  ( $P_{Dmax} = P_{INTmax} + P_{I/Omax}$ )
- $P_{INTmax}$  is the product of  $I_{DD}$  and  $V_{DD}$ , expressed in Watts. This is the maximum chip internal power.
- $P_{I/Omax}$  represents the maximum power dissipation on output pins

Where:

$$P_{I/Omax} = \Sigma (V_{OL} * I_{OL}) + \Sigma ((V_{DD} - V_{OH}) * I_{OH}),$$

taking into account the actual  $V_{OL}/I_{OL}$  and  $V_{OH}/I_{OH}$  of the I/Os at low and high level in the application.

**Table 25. Thermal characteristics<sup>(1)</sup>**

Symbol	Parameter	Value	Unit
$\Theta_{JA}$	Thermal resistance junction-ambient SO8 (Narrow)	130	°C/W
$\Theta_{JA}$	Thermal resistance junction-ambient UFDFPN 8 (2 x 3 mm)	120	°C/W

1. Thermal resistances are based on JEDEC JESD51-2 with 4-layer PCB in a natural convection environment.

### 10.2.1 Reference document

JESD51-2 integrated circuits thermal test method environment conditions - natural convection (still air). Available from [www.jedec.org](http://www.jedec.org).

# 11 Ordering information

## 11.1 STM8T141 ordering information scheme

Figure 26. STM8T141 ordering information scheme

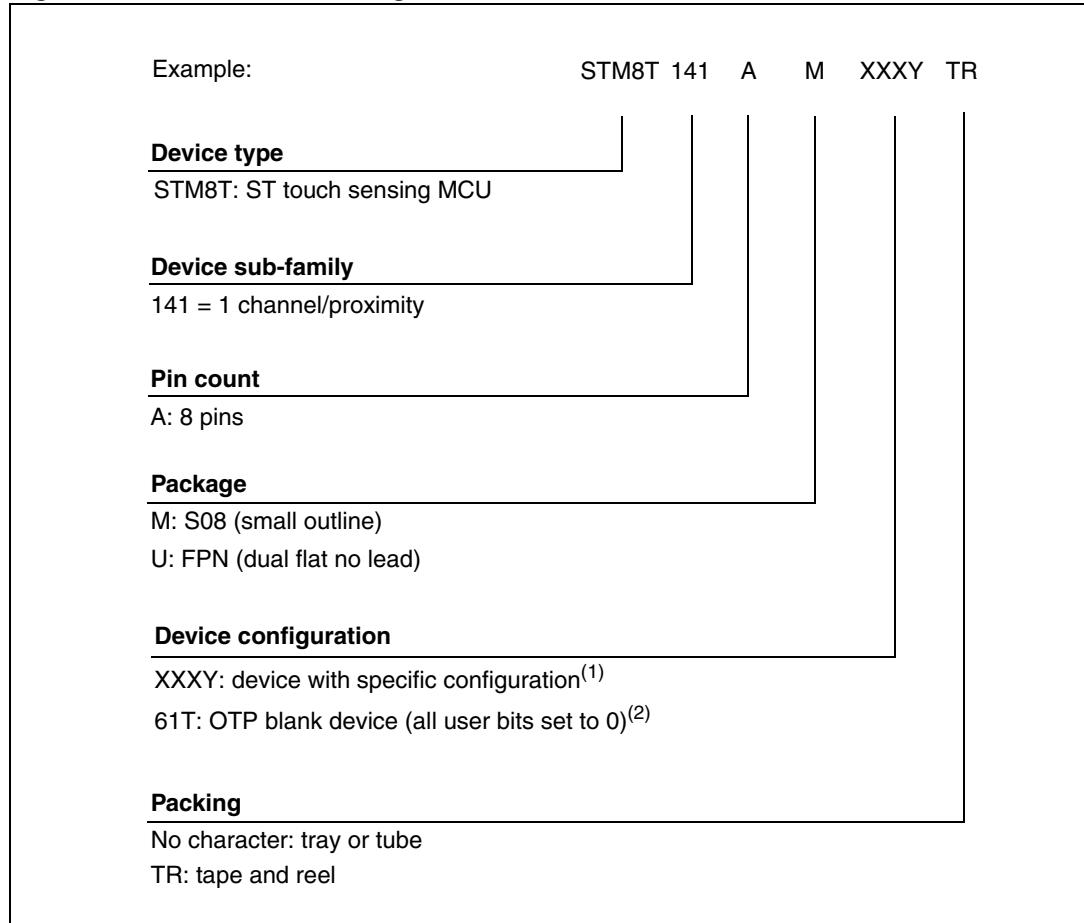

1. See [Table 26: Orderable favorite device lists](#) and the explanation below of “in factory option byte programming service”
2. The STM8T141 OTP devices are available for development. These parts are blank devices with unconfigured option bytes (all option bits are set to ‘0’). For more information, please refer to [Section 7: Device operation](#).

## 11.2 Orderable favorite device lists

**Table 26. Orderable favorite device lists**

Config.	Option byte configuration <sup>(1)</sup>						Part numbers	
	Sampling period	Charge transfer frequency	Power modes	Detection threshold	Reference freeze timeout	TOUT/ POUT output mode	SO8	UFDFPN8
Default config. (OTP)	20 ms	125 kHz	Low Power mode with zoom	Standard proximity	15 s	Active mode	STM8T141AM61T	STM8T141AU61TTR
	20 ms	125 kHz	Low Power mode with zoom	Sensitive touch	Infinite	Active mode	Not yet available	STM8T141AUMAJ1TR (XXXY = MAJ1)

1. Please refer to [Section 7: Device operation](#).

## 11.3 In-factory option byte programming service

For specific configurations not listed in [Table 26: Orderable favorite device lists](#), in-factory option byte programming is available on customer request and for large order quantities. Customers have to fill out the option list (see below) and send it back to STMicroelectronics. Customers are then informed by STMicroelectronics about the ordering part number corresponding to the customer configuration. The XXXY parameter of the final ordering part number (e.g. STM8T141AMXXXY) depends on the device configuration and is assigned by STMicroelectronics.

**STM8T141 programming service option list  
(last update: February 2010)**

**Customer name:**  
**Address:**

**Contact name:**  
**Phone number:**

Select the package type (tick one box)

STM8T141AM6 - S08  or STM8T141AU6 – DFN8

Customer settings (tick one box by option)
Sampling period (see <a href="#">Section 7.6: Sampling period</a> ) <input type="checkbox"/> 10 ms sampling period <input type="checkbox"/> 20 ms sampling period <sup>(1)</sup>
Charge transfer frequency (see <a href="#">Section 7.5: Charge transfer frequency</a> ) <input type="checkbox"/> 125 kHz <sup>(1)</sup> <input type="checkbox"/> 250 kHz
Power modes (see <a href="#">Section 7.4: Power modes</a> ) <input type="checkbox"/> Normal Power mode <input type="checkbox"/> Low Power mode with Zoom <sup>(1)</sup> <input type="checkbox"/> Extreme Low Power mode with Zoom <input type="checkbox"/> Extreme Low Power mode
Detection threshold (see <a href="#">Section 7.3: Detection threshold</a> ) <input type="checkbox"/> Sensitive proximity <input type="checkbox"/> Standard proximity <sup>(1)</sup> <input type="checkbox"/> Sensitive touch <input type="checkbox"/> Standard touch
Reference freeze timeout (see <a href="#">Section 5.3.2: Reference freeze timeout</a> ) <input type="checkbox"/> 15-second reference freeze timeout <sup>(1)</sup> <input type="checkbox"/> 45-second reference freeze timeout <input type="checkbox"/> Infinite reference freeze
TOUT/POUT output mode (see <a href="#">Section 7.2: TOUT/POUT output mode</a> ) <input type="checkbox"/> Active mode <sup>(1)</sup> <input type="checkbox"/> Toggle mode <input type="checkbox"/> 3-second Latch mode <input type="checkbox"/> 30-second Latch mode
Packaging <input type="checkbox"/> Tape & reel <input type="checkbox"/> Tube

Comment :

Date

Signature :

1. Configuration by default in OTP devices.

## 12 STM8T141 development tools

### STM8T141 evaluation kit

The STM8T141-EVAL is an evaluation kit which introduces developers to the STM8T141. It contains an STM8T141 evaluation board, plus a set of preconfigured plug-in modules which allow the STM8T141 device performances to be evaluated in either touch or proximity detection.

Figure 27. STM8T141-EVAL evaluation kit



### STM8T141 “blank” modules

An additional box of 10 STM8T141 “blank” modules (STM8T141AM-MOD) can be ordered separately, where the device option bytes are left unprogrammed (see [Figure 28](#)).

**Figure 28. STM8T141 blank module box**



1. The above figure is not binding.

**Programming tool**

Figure 29 shows the STM8T141-EVAL programming tool.

To program the device option bytes so that the device can be tested in different configurations, the following materials are available:

- A programming socket board (STM8T141-SB). When connected to the programming dongle, this board allows SO8 and DFN8 devices as well as plug-in modules delivered in the evaluation kit to be programmed.
- A programming dongle (ST-TSLINK) and its associated programming software, STVP.

**Figure 29. STM8T141-EVAL programming tool**

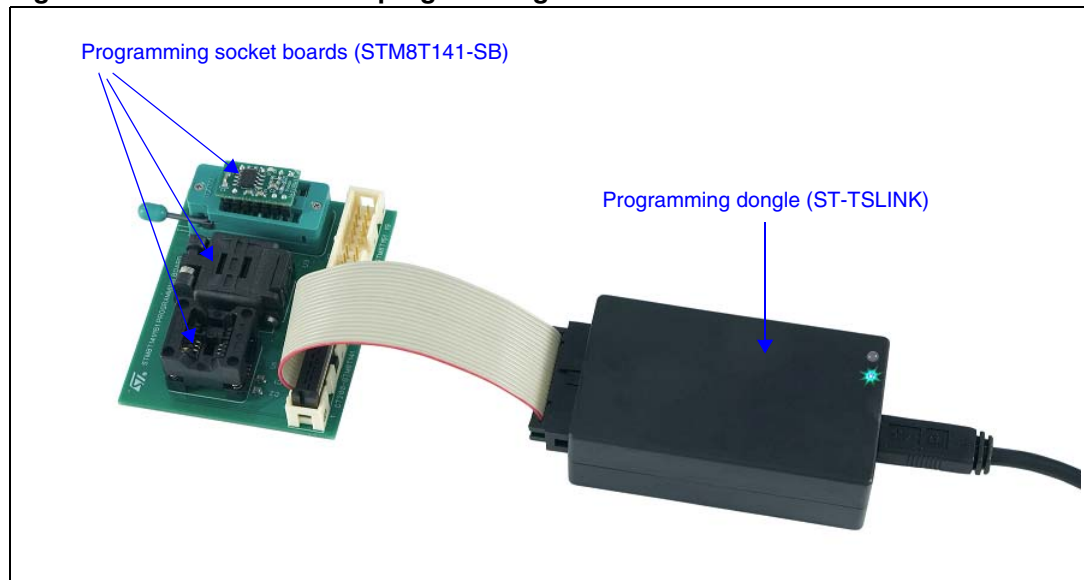

**Ordering information**

**Table 27. Ordering information**

Part number	Order codes	Description
STM8T1X1-EVAL	STM8T141-EVAL	STM8T141 evaluation kit
STM8T-MOD	STM8T141AM-MOD	Box containing 10 blank modules based on STM8T141AM61T (OTP device in SO8 package)
ST-TSLINK	ST-TSLINK <sup>(1)</sup>	STM8T141 programming dongle
STM8T1X1-SB	STM8T141-SB <sup>(1)</sup>	STM8T141 socket board

1. The ST-TSLINK dongle and the STM8T141-SB socket board are not part of the STM8T141-EVAL evaluation kit, and consequently must be ordered separately.

## 13 Revision history

**Table 28. Document revision history**

Date	Revision	Changes
09-Jun-2009	1	Initial release.
02-Jul-2009	2	V <sub>DD</sub> range changed to 2.9 to 5.5V. <a href="#">Table 12</a> and <a href="#">Table 14</a> updated. Internal voltage regulator bypassed configuration removed. I <sub>DDL</sub> P removed from <a href="#">Table 13</a> .
31-Jul-2009	3	Upgraded document from Preliminary Data to full Datasheet. Updated oscillator information in <a href="#">Figure 1: STM8T141 block diagram on page 8</a> . Added detection threshold values in <a href="#">Table 16: General capacitive sensing characteristics on page 33</a> . Updated values in <a href="#">Table 17: Response times on page 34</a> .
05-Oct-2009	4	Updated <a href="#">Section 11: Ordering information</a> . <a href="#">Section 11.2: Orderable favorite device lists</a> : added information on option byte programming; added option list. Added <a href="#">Section 12: STM8T141 development tools</a>
24-Feb-2010	5	Lower operating supply voltage changed from 2.9 V to 2.0 V. The following tables were impacted: <a href="#">Table 1: Device summary</a> , <a href="#">Table 12: Operating characteristics</a> , <a href="#">Table 13: Average current consumption without shield</a> , <a href="#">Table 16: General capacitive sensing characteristics</a> , and <a href="#">Table 16: General capacitive sensing characteristics</a> . Introduced trademark for ProxSense (ProxSense™) Throughout document, “sensitivity threshold or level” replaced with “detection threshold”, “automatic recalibration” with “reference freeze timeout”, “S <sub>TH</sub> ” with “D <sub>TH</sub> ”, and “SO” with “SO8”. <a href="#">Section 2: Block diagram</a> : replaced ‘capacitive sensing engine’ with ‘ProxSense engine’. Added <a href="#">Figure 3: UDFPN8 pinout</a> . Updated <a href="#">Table 2: STM8T141 pin descriptions</a> . Renamed <a href="#">Section 4</a> as <a href="#">STM8T ProxSense technology</a> Renamed <a href="#">Section 4.2</a> as <a href="#">Charge transfer acquisition principle</a> and updated text. <a href="#">Figure 5: STM8T measuring circuitry</a> : updated. <a href="#">Figure 6: Conversion period examples</a> : updated. Sections 4.3 renamed <a href="#">Section 5: STM8T processing</a> . Section re-organised and reworked with new figures and tables added. <a href="#">Section 6: Typical application diagram</a> : removed introductory text; modified <a href="#">Figure 10</a> , modified footnote 1, added footnote 2, added text regarding R <sub>SHIELD</sub> resistor, define a touch or proximity detection. <a href="#">Section 7: Device operation</a> : Re-organisation of text; removed reference related to low power modes. <a href="#">Section 7.1: Option byte description</a> : added reference to <a href="#">Section 12</a> . <a href="#">Table 5: Option bytes</a> : updated factory default setting of OPT1, recalibration timeout renamed reference freeze timeout.

Table 28. Document revision history (continued)

Date	Revision	Changes
24-Feb-2010	5 cont'd	<p><a href="#">Section 7.2.1</a>, <a href="#">Section 7.2.2</a>, <a href="#">Section 7.2.3</a>, and <a href="#">Section 7.2.4</a>: replaced “output configuration” with “output operation”.</p> <p><a href="#">Section 7.2.3: 3-second latch</a>: removed some text concerning the TOUT/POUT pin.</p> <p>Renamed <a href="#">Section 7.3: Detection threshold</a>.</p> <p><a href="#">Section 7.4: Power modes</a>: small text changes; <a href="#">Table 8</a> moved to this section from <a href="#">Section 7.4.4: Extreme Low Power mode</a>.</p> <p><a href="#">Section 8.1: Shield function</a>: removed text about <math>R_{SHIELD}</math>.</p> <p><a href="#">Figure 20: Connecting the shield (coaxial cable implementation)</a>: amended ohm symbol.</p> <p><a href="#">Section 8.2: Sensitivity adjustment</a>: added text regarding sensitivity; updated bullet points.</p> <p>Added <a href="#">Section 8.3: Influence of power supply variation</a>.</p> <p><a href="#">Table 12: Operating characteristics</a>: added <math>t_{VDD}</math> data.</p> <p><a href="#">Section 9.3.2: Average current consumption</a>: for test conditions, 100 nF replaced with 47 nF; modified <a href="#">Table 13</a> and note underneath it; added <a href="#">Figure 22</a>.</p> <p><a href="#">Table 14: Output pin characteristics</a>: removed <math>t_{VDD}</math> data.</p> <p>Added <a href="#">Section 9.4: Regulator and reference voltage</a> and <a href="#">Table 15</a>.</p> <p><a href="#">Section 9.5: Capacitive sensing characteristics</a>: amended <a href="#">Table 16</a> for values of <math>f_{TRANSFER}</math>, <math>t_{RFT}</math>, and <math>t_{BURST}</math>; updated symbols for <math>t_{RFT}</math>, <math>D_{Th}</math>, and <math>\sigma</math>; added <a href="#">Figure 23</a>.</p> <p><a href="#">Table 18: External sensing component characteristics</a>: modified <math>C_S</math> parameter and <math>R_{SHIELD}</math> min value.</p> <p><a href="#">Section 11: Ordering information</a>: updated <a href="#">Figure 26</a>; added <a href="#">Section 11.2</a> and <a href="#">Section 11.3</a>.</p> <p><a href="#">Section 11.2: Orderable favorite device lists</a>: updated ordering part number; added footnote to option list concerning default configuration of OPT devices, added packaging information to the option list, updated headings and date.</p> <p><a href="#">Section 12: STM8T141 development tools</a>: replaced STM8T1X1 with STM8T141.</p>
01-Apr-2010	6	Added that ProxSense™ is a trademark of Azoteq.

**Please Read Carefully:**

Information in this document is provided solely in connection with ST products. STMicroelectronics NV and its subsidiaries ("ST") reserve the right to make changes, corrections, modifications or improvements, to this document, and the products and services described herein at any time, without notice.

All ST products are sold pursuant to ST's terms and conditions of sale.

Purchasers are solely responsible for the choice, selection and use of the ST products and services described herein, and ST assumes no liability whatsoever relating to the choice, selection or use of the ST products and services described herein.

No license, express or implied, by estoppel or otherwise, to any intellectual property rights is granted under this document. If any part of this document refers to any third party products or services it shall not be deemed a license grant by ST for the use of such third party products or services, or any intellectual property contained therein or considered as a warranty covering the use in any manner whatsoever of such third party products or services or any intellectual property contained therein.

**UNLESS OTHERWISE SET FORTH IN ST'S TERMS AND CONDITIONS OF SALE ST DISCLAIMS ANY EXPRESS OR IMPLIED WARRANTY WITH RESPECT TO THE USE AND/OR SALE OF ST PRODUCTS INCLUDING WITHOUT LIMITATION IMPLIED WARRANTIES OF MERCHANTABILITY, FITNESS FOR A PARTICULAR PURPOSE (AND THEIR EQUIVALENTS UNDER THE LAWS OF ANY JURISDICTION), OR INFRINGEMENT OF ANY PATENT, COPYRIGHT OR OTHER INTELLECTUAL PROPERTY RIGHT.**

**UNLESS EXPRESSLY APPROVED IN WRITING BY AN AUTHORIZED ST REPRESENTATIVE, ST PRODUCTS ARE NOT RECOMMENDED, AUTHORIZED OR WARRANTED FOR USE IN MILITARY, AIR CRAFT, SPACE, LIFE SAVING, OR LIFE SUSTAINING APPLICATIONS, NOR IN PRODUCTS OR SYSTEMS WHERE FAILURE OR MALFUNCTION MAY RESULT IN PERSONAL INJURY, DEATH, OR SEVERE PROPERTY OR ENVIRONMENTAL DAMAGE. ST PRODUCTS WHICH ARE NOT SPECIFIED AS "AUTOMOTIVE GRADE" MAY ONLY BE USED IN AUTOMOTIVE APPLICATIONS AT USER'S OWN RISK.**

Resale of ST products with provisions different from the statements and/or technical features set forth in this document shall immediately void any warranty granted by ST for the ST product or service described herein and shall not create or extend in any manner whatsoever, any liability of ST.

ST and the ST logo are trademarks or registered trademarks of ST in various countries.

Information in this document supersedes and replaces all information previously supplied.

The ST logo is a registered trademark of STMicroelectronics. All other names are the property of their respective owners.

© 2010 STMicroelectronics - All rights reserved

STMicroelectronics group of companies

Australia - Belgium - Brazil - Canada - China - Czech Republic - Finland - France - Germany - Hong Kong - India - Israel - Italy - Japan - Malaysia - Malta - Morocco - Philippines - Singapore - Spain - Sweden - Switzerland - United Kingdom - United States of America

[www.st.com](http://www.st.com)