

2 POLYMER ALUMINUM ELECTROLYTIC CAPACITORS

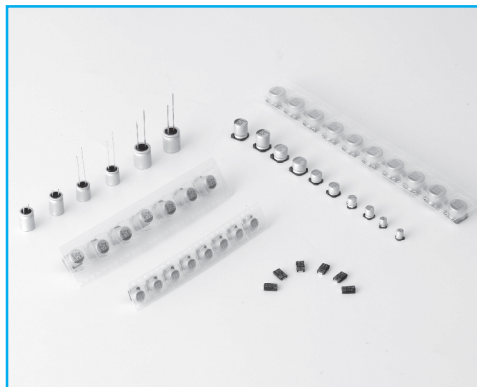

Hi-CAP (Conductive Polymer Aluminum Electrolytic Capacitor)

Hi-CAP is an electrolytic capacitor that uses a highly electric conductive polymer as its electrolyte.

Hi-CAP has excellent temperature and load life characteristics due to adoption of stable polymer in high temperature.

Compared to other electrolytic capacitors, the **Hi-CAP** is a low impedance capacitor suitable for high frequency making it ideal for digital circuit.

1. Circuit design

- (1) The conducting polymer capacitor cannot be used in circuits that undergo frequent charging and discharging because the resulting internal heat buildup can cause capacitor failure.
- (2) Do not use the capacitor in time-constant or coupling circuits. In these type of circuit, electrical characteristics such as capacitance can change under certain environmental conditions.

2. Capacitor handling techniques

(1) Capacitor insertion

Incorrect land size may cause problems with capacitor placement and mountability.

Refer to the land size table for appropriate design dimensions.

(2) Soldering

When using a soldering iron, set the tip temperature to no more than 300°C, and work in as short a time as possible under 10 seconds. While soldering, do not apply strong force to the capacitor.

Reflow soldering

The conducting polymer capacitor is designed specifically for reflow soldering.

Maintain soldering conditions (pre-heating, reflow temperature, time) within the range indicated in the product specifications. If soldering time is lengthened or temperature is higher, the heat can damage the capacitor element and / or the molded case.

Do not perform reflow soldering more than twice.

(3) Circuit board cleaning

Capacitors can withstand immersion in solvent at 60°C or under for up to 5 minutes.

Be sure to sufficiently wash (about 3 min. with water) and dry (20 min. at 100°C) the board afterward.

3. Electrical characteristics comparison of Capacitors

Species	High Frequency	Temperature	Allowable ripple	Miniaturized
Al Electrolytic capacitor	○	○	⊙	●
MLCC	●	○	—	⊙
Film Capacitor	●	●	—	○
Tantal Capacitor	⊙	⊙	○	⊙
Hi-CAP	●	●	●	⊙

※ ● Superior ⊙ Ordinary ○ Inferior

● Taping Specifications for SMD Type Polymer Capacitors (Vertical type)

● Carrier Tape

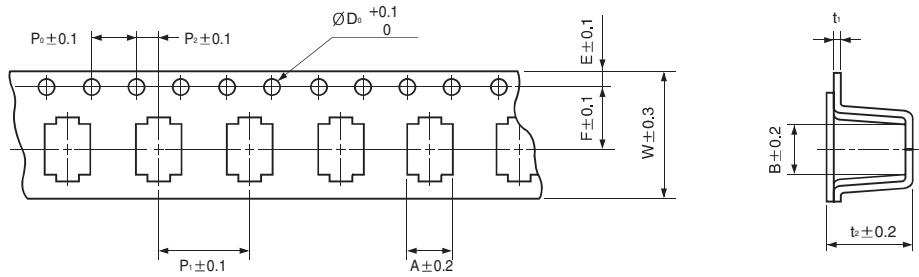

ØD×L	A	B	ØD ₀	E	F	P ₀	P ₁	P ₂	t ₁	t ₂	W
4×5.4	4.7	4.7	1.5	1.75	5.5	4	8	2	0.4	5.7	12
5×5.9	5.6	5.6	1.5	1.75	5.5	4	8	2	0.4	6.3	16
6.3×4.5	6.9	6.9	1.5	1.75	7.5	4	12	2	0.4	5.7	16
6.3×5.9	6.9	6.9	1.5	1.75	7.5	4	12	2	0.4	6.3	16
8×6.9	8.6	8.6	1.5	1.75	11.5	4	12	2	0.4	7.2	24
8×11.9	8.6	8.6	1.5	1.75	11.5	4	16	2	0.4	12.3	24
10×7.9	10.7	10.7	1.5	1.75	11.5	4	16	2	0.4	8.2	24
10×12.6	10.7	10.7	1.5	1.75	11.5	4	16	2	0.4	13	24

● Reel(Taping Code : VR)

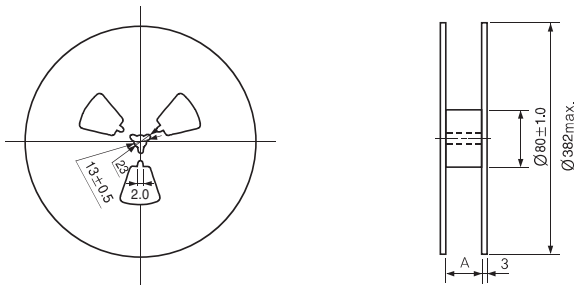

ØD×L	A
4×5.4	14
5×5.9	18
6.3×4.5	18
6.3×5.9	18
8×6.9	26
8×11.9	26
10×7.9	26
10×12.6	26

ØD×L	Q'ty/Reel(pcs)	Q'ty/Box(pcs)
4×5.4	2000	20000
5×5.9	1500	15000
6.3×4.5	1000	10000
6.3×5.9	1000	10000
8×6.9	1000	10000
8×11.9	400	4000
10×7.9	500	5000
10×12.6	400	4000

● Recommended Land Size

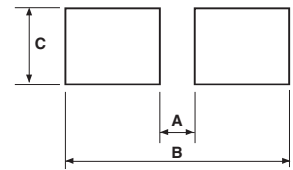

ØD×L	A	B	C
4×5.4	1.0	6.2	1.6
5×5.9	1.4	7.4	1.6
6.3×4.5	2.1	9.1	1.6
6.3×5.9	2.1	9.1	1.6
8×6.9	2.8	11.1	1.9
10×7.9	4.3	13.1	1.9
8×11.9	2.8	11.1	1.9
10×12.6	4.3	13.1	1.9

● Recommendable reflow soldering temperature

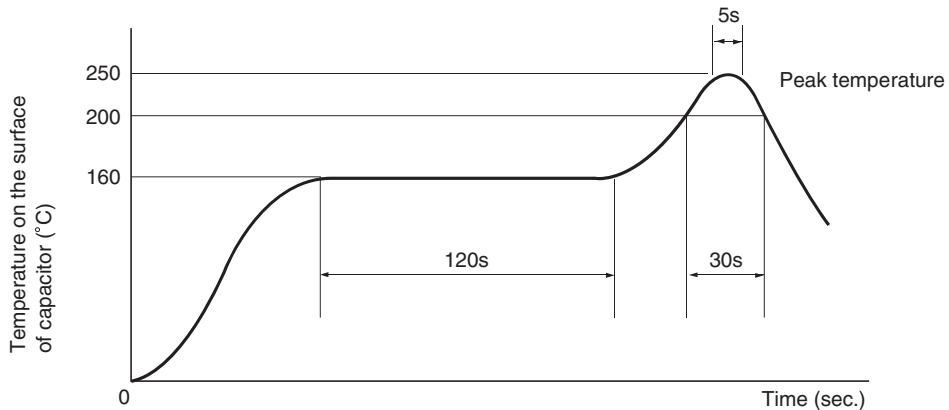

SOLID TYPES

CONDUCTIVE POLYMER ALUMINUM ELECTROLYTIC CAPACITORS

● Taping Specifications for Lead Type Polymer Capacitors

DRAWING I

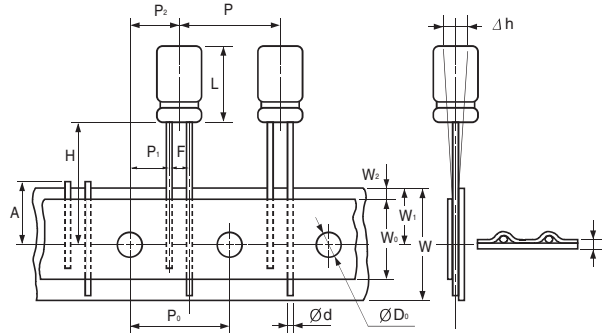

Applicable Drawing No.			I			
Description	Symbol	Tolerance	Ø6.3	Ø8		Ø10
Body Height	L	+1	6	9	12	13
Lead Dia.	Ød	±0.05	0.45	0.60	0.60	0.6
Body Pitch	P	±1.0	12.7			
Feeding Hole Pitch	P ₀	±0.2	12.7			
Feeding Hole Alignment	P ₁	±0.7	5.1			3.85
Feeding Hole Alignment	P ₂	±1.0	6.35			
Lead Center Spacing	F	+0.6/-0.2	2.5	3.5		5.0
Body Inclination	Δh	±2.0	0			
Tape Width	W	±0.5	18.0			
Adhesive Tape Width	W ₀	min.	7.0			
Feeding Hole Alignment	W ₁	±0.5	9.0			
Adhesive Tape Margin	W ₂	max.	2.0			
Length from Seating Plane	H	±0.5	17.5	20		18.5
Feeding Hole Dia.	ØD ₀	±0.2	4.0			
Total Tape Thickness	t	±0.2	0.7			
Cut Lead Height	A	max.	11.0			
Taping Code	Ammo	⊕ leader	PC	PF	PA	

● PACKAGING Q'ty(pcs.) / BOX

Size		Ammo			
ØD	Case Height	L	H	W	Q'ty
6.3	6	332	230	42	1500
8	9	332	230	49	1000
	12	332	230	49	1000
10	13	332	190	51	500

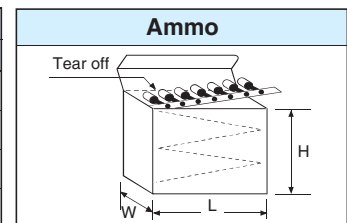

● BULK PACKING QUANTITY(PCS) / BOX

Size		V-BAG	INNER BOX	MIDDLE BOX
D	L			
6.3	6	750	6000	24000
	8	750	6000	24000
8	9	400	3200	12800
	12	400	3200	12800
10	13	250	1500	6000

● CUTTING PACKING QUANTITY(PCS) / BOX

Size		V-BAG	INNER BOX	MIDDLE BOX
D	L			
6.3	6	750	6000	24000
	8	750	6000	24000
8	9	500	4000	16000
	12	400	3200	12800
10	13	250	1500	6000

● Taping Specifications for SMD type Polymer Capacitors (Horizontal type)

● Carrier Tape

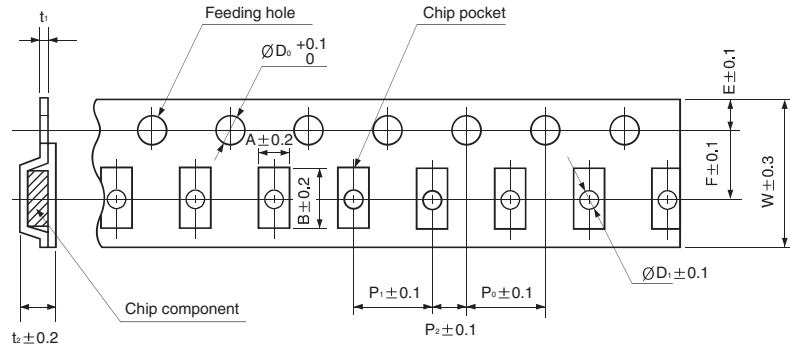

Size code	A	B	ØD ₀	ØD ₁	E	F	P ₀	P ₁	P ₂	t ₁	t ₂	W
A	4.7	7.7	1.5	1.6	1.75	5.5	4.0	8.0	2.0	0.3	2.2	12.0
C	4.7	7.7	1.5	1.6	1.75	5.5	4.0	8.0	2.0	0.3	3.4	12.0
D	4.7	7.7	1.5	1.6	1.75	5.5	4.0	8.0	2.0	0.3	4.5	12.0

● Packaging Specifications

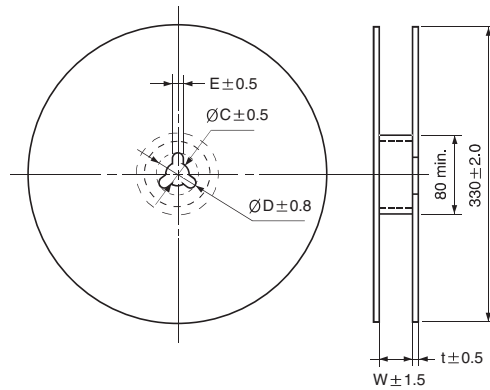

Size code	Q'ty / Reel
A	3000 pcs.
C	2000 pcs.
D	2000 pcs.

ØC	ØD	E	W	t
13.0	21.0	2.0	14.0	2.0

● Recommendable reflow soldering temperature

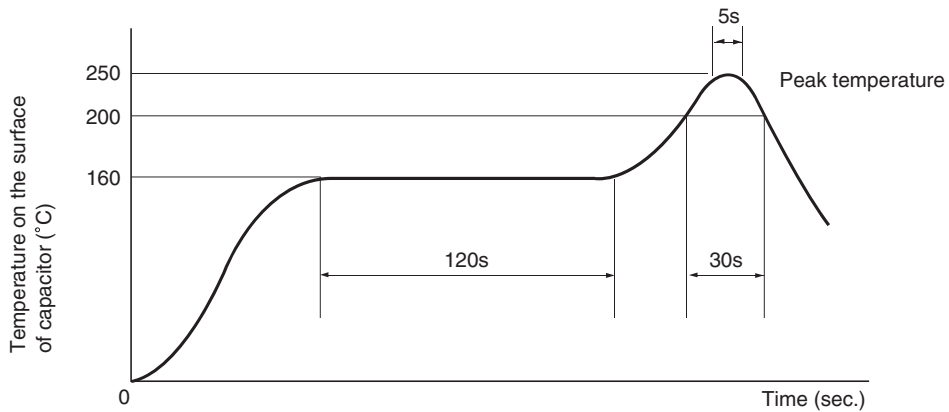

CONDUCTIVE POLYMER ALUMINUM ELECTROLYTIC CAPACITORS

FA Chip type, With Conductive Polymer Series

Hi-CAP

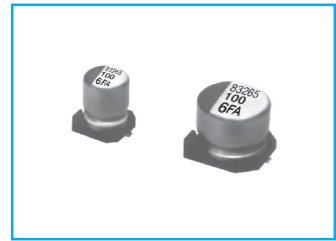

- Low ESR, high ripple current
- Designed for surface mounting on high density PC board
- Load life for 2000 hours at 105°C
- Complied to the RoHS directive



Item	Characteristics	
Operating temperature range	-55 ~ +105°C	
Leakage current max.*	Less than or equal to the value of Table1	
Capacitance tolerance	±20% at 120Hz, 20°C	
Dissipation factor max.	Less than or equal to the value of Table1	
ESR	Less than or equal to the value of Table1	
Temperature characteristics (Impedance ratio at 100kHz)	Z-55°C / Z+20°C	Z+105°C / Z+20°C
	0.75~1.25	0.75~1.25
Load life (after application of the rated voltage for 2000 hours at 105°C, In case of 25WV is applied 20V)	Leakage current	Less than specified value
	Capacitance change	Within ±20% of initial value
	tanδ	Less than 150% of specified value
Resistance to soldering heat (Refer to Page 25 for soldering recommendation)	Leakage current	Less than specified value
	Capacitance change	Within ±10% of initial value
	tanδ	Less than 130% of specified value

* In case of some problems for measured values, measure after applying rated voltage for 2.5 to 20V products or 20V derating voltage for 25V products for 120 minutes at 105°C.

DRAWING

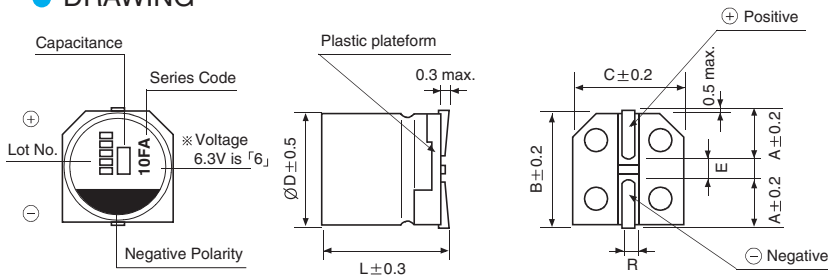

Unit : mm

PART NUMBER SYSTEM (See Page 46)

Size	∅D	L	B	C	E	A	R
4×5.4	4	5.4	4.3	4.3	1.0	1.9	0.5~0.8
5×5.9	5	5.9	5.3	5.3	1.4	2.2	0.5~0.8
6.3×5.9	6.3	5.9	6.6	6.6	2.2	2.45	0.5~0.8
8×6.9	8	6.9	8.3	8.3	3.2	2.9	0.5~0.8
8×11.9	8	11.9	8.3	8.3	3.2	2.9	0.8~1.1
10×7.9	10	7.9	10.3	10.3	4.6	3.2	0.8~1.1
10×12.6	10	12.6	10.3	10.3	4.6	3.2	0.8~1.1

DIMENSIONS

µF	WV(SV)	2.5(3.3)	4(5.2)	6.3(8.2)	10(11.5)	16(18.4)	20(23)	25(25)
3.3						4 × 5.4		
4.7					4 × 5.4			
6.8					4 × 5.4			6.3 × 5.9
10					4 × 5.4		5 × 5.9	8 × 6.9
15					4 × 5.4	5 × 5.9		
22				4 × 5.4		5 × 5.9		10 × 7.9
27							6.3 × 5.9	
33			4 × 5.4		5 × 5.9		8 × 6.9	8 × 11.9
39			5 × 5.9			6.3 × 5.9		
47				5 × 5.9	6.3 × 5.9		8 × 6.9	
56					6.3 × 5.9	8 × 6.9	10 × 7.9	10 × 12.6
68			5 × 5.9				10 × 7.9	
82				6.3 × 5.9		8 × 6.9		
100				6.3 × 5.9		10 × 7.9	8 × 11.9	
120				6.3 × 5.9				
150			★ 8 × 6.9		○ 10 × 7.9		10 × 12.6	
180						● 8 × 11.9		
220	6.3 × 5.9			○ 10 × 7.9				
270					10 × 7.9			
330			8 × 6.9	10 × 7.9	● 8 × 11.9	10 × 12.6		
470				● 8 × 11.9				
560			8 × 11.9		10 × 12.6			
680	8 × 11.9		10 × 7.9	10 × 12.6				
820								
1200			10 × 12.6					
1500	10 × 12.6							

★Size ∅6.3×5.9 is available ○Size ∅8×6.9 is available ●Size ∅10×7.9 is available

FA Series

● Table1. FA(SMD type) Series Characteristics List

WV	μF	∅D(mm)	L(mm)	ESR(mΩ)max. 100~300kHz	Ripple current (mA rms)at 105°C 100kHz	Dissipation factor 120Hz	Leakage Current (μA)(max.) after 2 minutes
2.5	220	6.3	5.9	23	2390	0.12	110
2.5	680	8	11.9	13	4520	0.15	340
2.5	1500	10	12.6	12	5440	0.18	750
4	33	4	5.4	200	740	0.15	66
4	39	5	5.9	70	1100	0.12	78
4	68	5	5.9	60	1400	0.12	136
4	150	6.3	5.9	40	1810	0.12	120
4	150	8	6.9	35	2560	0.12	120
4	330	8	6.9	35	2560	0.12	264
4	680	10	7.9	25	3700	0.12	544
4	560	8	11.9	13	4520	0.15	448
4	1200	10	12.6	12	5440	0.18	960
6.3	22	4	5.4	200	740	0.12	69.3
6.3	47	5	5.9	70	1100	0.12	148
6.3	82	6.3	5.9	45	1700	0.12	103
6.3	100	6.3	5.9	40	1810	0.12	126
6.3	120	6.3	5.9	17	2780	0.12	151
6.3	220	8	6.9	35	2560	0.12	277
6.3	220	10	7.9	25	3700	0.12	277
6.3	330	10	7.9	25	3700	0.12	416
6.3	470	10	7.9	25	3700	0.12	592
6.3	470	8	11.9	15	4210	0.12	592
6.3	820	10	12.6	12	5440	0.15	775
10	4.7	4	5.4	240	670	0.08	23.5
10	6.8	4	5.4	240	670	0.08	34
10	10	4	5.4	220	700	0.09	50
10	15	4	5.4	200	740	0.10	75
10	33	5	5.9	70	1100	0.10	165
10	47	6.3	5.9	50	1620	0.12	94
10	56	6.3	5.9	45	1700	0.12	112
10	120	8	6.9	35	2560	0.12	240
10	150	8	6.9	35	2560	0.12	300
10	150	10	7.9	30	3020	0.12	300
10	270	10	7.9	25	3700	0.12	540
10	330	10	7.9	25	3700	0.12	660
10	330	8	11.9	17	3950	0.15	660
10	560	10	12.6	13	5230	0.15	840
16	3.3	4	5.4	260	660	0.07	26.4
16	15	5	5.9	120	1020	0.10	120
16	22	5	5.9	90	1060	0.10	176
16	39	6.3	5.9	50	1620	0.10	125
16	56	8	6.9	45	1890	0.12	179
16	82	8	6.9	40	2120	0.12	262
16	100	10	7.9	35	2670	0.12	320
16	150	10	7.9	30	3020	0.12	480
16	180	10	7.9	30	3020	0.12	576
16	180	8	11.9	20	3640	0.15	576
16	330	10	12.6	16	4720	0.15	792
20	10	5	5.9	120	1020	0.10	100
20	22	6.3	5.9	60	1450	0.10	88
20	27	6.3	5.9	60	1450	0.10	108
20	33	8	6.9	45	1890	0.12	132
20	47	8	6.9	45	1890	0.12	188
20	56	10	7.9	40	2400	0.12	224
20	68	10	7.9	40	2400	0.12	272
20	100	8	11.9	24	3320	0.15	400
20	150	10	12.6	20	4320	0.15	600
25	6.8	6.3	5.9	80	1200	0.10	85
25	10	8	6.9	60	1500	0.10	125
25	22	10	7.9	50	2000	0.10	275
25	33	8	11.9	30	2980	0.12	413
25	56	10	12.6	28	3800	0.12	700

SOLID TYPES

CONDUCTIVE POLYMER ALUMINUM ELECTROLYTIC CAPACITORS

FH Chip type, Large Capacitance, Low ESR Series

Hi-CAP



- Large capacitance, Low ESR than FA Series
- Complied to the RoHS directive



Item	Characteristics	
Operating temperature range	-55 ~ +105°C	
Leakage current max.*	Less than or equal to the value of Table1	
Capacitance tolerance	±20% at 120Hz, 20°C	
Dissipation factor max.	Less than or equal to the value of Table1	
ESR	Less than or equal to the value of Table1	
Temperature characteristics (Impedance ratio at 100kHz)	Z-55°C / Z+20°C	Z+105°C / Z+20°C
	0.75~1.25	0.75~1.25
Load life (after application of the rated voltage for 2000 hours at 105°C)	Leakage current	Less than specified value
	Capacitance change	Within ±20% of initial value
	ESR	Less than 150% of specified value
	tanδ	Less than 150% of specified value
Resistance to soldering heat (Refer to Page 25 for soldering recommendation)	Leakage current	Less than specified value
	Capacitance change	Within ±10% of initial value
	tanδ	Less than 130% of specified value

* In case of some problems for measured values, measure after applying rated voltage for 120 minutes at 105°C.

DRAWING

Unit : mm

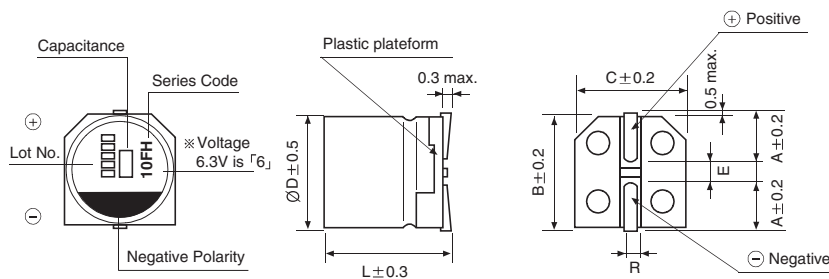

PART NUMBER SYSTEM (See Page 46)

Size	ØD	L	B	C	E	A	R
5×5.9	5	5.9	5.3	5.3	1.4	2.2	0.5~0.8
6.3×5.9	6.3	5.9	6.6	6.6	2.2	2.45	0.5~0.8
8×6.9	8	6.9	8.3	8.3	3.2	2.9	0.5~0.8
8×11.9	8	11.9	8.3	8.3	3.2	2.9	0.8~1.1
10×12.6	10	12.6	10.3	10.3	4.6	3.2	0.8~1.1

DIMENSIONS

µF	WV(SV)	2.5(3.3)	4(5.2)	6.3(8.2)	10(11.5)	16(18.4)
39						5 × 5.9
68					5 × 5.9	6.3 × 5.9
100				5 × 5.9		
120					6.3 × 5.9	8 × 6.9
150			5 × 5.9			
180		5 × 5.9				
220				6.3 × 5.9		
270					8 × 6.9	
330			6.3 × 5.9			
390		6.3 × 5.9		8 × 6.9		
470						10 × 12.6
560			8 × 6.9		10 × 12.6	
			8 × 11.9			
680		8 × 6.9				
820		8 × 11.9				
1200			8 × 11.9			
1500		8 × 11.9	8 × 11.9			
2700		10 × 12.6				
3300		10 × 12.6				

← Case size ØD×L(mm)

FH Series

● Table 1. FH(SMD type) Series Characteristics List

WV	μF	ØD(mm)	L(mm)	ESR(mΩ)max. 100~300kHz	Ripple current (mA rms)at 105°C 100kHz	Dissipation factor 120Hz	Leakage Current (μA)(max.) after 2 minutes
2.5	180	5	5.9	24	2200	0.12	300
2.5	390	6.3	5.9	25	2410	0.12	300
2.5	390	6.3	5.9	10	3900	0.12	500
2.5	680	8	6.9	20	3370	0.12	500
2.5	680	8	6.9	9	4500	0.12	500
2.5	820	8	11.9	9	5380	0.15	500
2.5	1500	8	11.9	10	5150	0.15	750
2.5	2700	10	12.6	12	5080	0.15	1350
2.5	3300	10	12.6	8	6650	0.15	1650
4	150	5	5.9	23	2240	0.12	300
4	330	6.3	5.9	21	2630	0.12	300
4	330	6.3	5.9	10	3900	0.12	500
4	560	8	6.9	22	3220	0.12	500
4	560	8	6.9	9	4500	0.12	672
4	560	8	11.9	9	5380	0.15	500
4	1200	8	11.9	12	4700	0.15	960
4	1500	8	11.9	12	4700	0.15	1200
6.3	100	5	5.9	25	2150	0.12	300
6.3	220	6.3	5.9	15	3110	0.12	300
6.3	220	6.3	5.9	10	3900	0.12	500
6.3	390	8	6.9	22	3220	0.12	491
6.3	390	8	6.9	9	4500	0.12	737
6.3	820	8	11.9	12	4700	0.15	1033
10	68	5	5.9	30	1970	0.12	300
10	120	6.3	5.9	27	2320	0.12	300
10	270	8	6.9	22	3220	0.12	500
10	560	10	12.6	10	5650	0.10	1120
16	39	5	5.9	35	1820	0.12	300
16	68	6.3	5.9	30	2200	0.12	300
16	120	8	6.9	27	2900	0.12	500
16	470	10	12.6	10	6100	0.10	1504

CONDUCTIVE POLYMER ALUMINUM ELECTROLYTIC CAPACITORS

FT Chip type, Guaranteed at 125°C Series

Hi-CAP

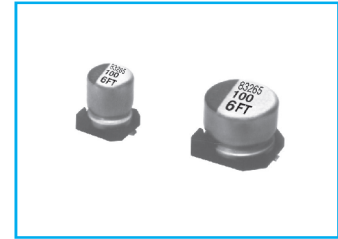

- The FT Series is very reliable, guaranteeing performance
- Suitable for use in smoothing circuits of vehicle-mounted equipment, industrial equipment, etc
- Complied to the RoHS directive

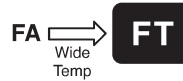

Item	Characteristics	
Operating temperature range	-55 ~ +125°C	
Leakage current max.*	Less than or equal to the value of Table1	
Capacitance tolerance	±20% at 120Hz, 20°C	
Dissipation factor max.	Less than or equal to the value of Table1	
ESR	Less than or equal to the value of Table1	
Temperature characteristics (Impedance ratio at 100kHz)	Z-55°C / Z+20°C	Z+125°C / Z+20°C
	0.75~1.25	0.75~1.25
Load life (after application of the rated voltage for 2000 hours at 125°C)	Leakage current	Less than specified value
	Capacitance change	Within ±20% of initial value
	ESR	Less than 200% of specified value
	tanδ	Less than 200% of specified value
Resistance to soldering heat (Refer to Page 25 for soldering recommendation)	Leakage current	Less than specified value
	Capacitance change	Within ±10% of initial value
	tanδ	Less than 130% of specified value

* In case of some problems for measured values, measure after applying rated voltage for 120 minutes at 125°C.

● DRAWING (See Page 29)

Unit : mm

● DIMENSIONS

WV(SV) µF	10(11.5)	16(18.4)	25(29)	35(40)
8.2				8 × 6.9
10			6.3 × 5.9	
18				10 × 7.9
22			8 × 6.9	8 × 11.9
39			10 × 7.9	
47			8 × 11.9	10 × 12.6
56	6.3 × 5.9			
82		8 × 6.9	10 × 12.6	← Case size ØD×L(mm)

● Table 1. FT(SMD type) Series Characteristics List

WV	µF	ØD (mm)	L(mm)	ESR(mΩ)max. 100~300kHz	Rated ripple current (100kHz)(mA _{rms}) 105°C < T _x ≤ 125°C	Allowable ripple current (100kHz)(mA _{rms}) T _x ≤ 105°C	Dissipation factor 120Hz	Leakage Current (µA)(max.) after 2 minutes
10	56	6.3	5.9	45	538	1700	0.12	112
16	82	8	6.9	40	670	2120	0.12	262
25	10	6.3	5.9	65	474	1500	0.10	50
25	22	8	6.9	48	580	1835	0.10	110
25	39	10	7.9	45	664	2100	0.10	195
25	47	8	11.9	30	943	2980	0.12	235
25	82	10	12.6	28	1202	3800	0.12	410
35	8.2	8	6.9	70	400	1300	0.10	57
35	18	10	7.9	60	550	1800	0.10	126
35	22	8	11.9	50	700	2300	0.12	154
35	47	10	12.6	30	1150	3650	0.12	329

FZ Chip type, Guaranteed at 105°C 5000hrs Series

- Series has long life time than the FA Series
- Suitable for use in flat panel TV set(PDP,LCD) and the others industrial equipments, etc
- Complied to the RoHS directive

Hi-CAP



FA → FZ
Long life

Item	Characteristics	
Operating temperature range	-55 ~ +105°C	
Leakage current max.*	Less than or equal to the value of Table1	
Capacitance tolerance	±20% at 120Hz, 20°C	
Dissipation factor max.	Less than or equal to the value of Table1	
ESR	Less than or equal to the value of Table1	
Temperature characteristics (Impedance ratio at 100kHz)	Z-55°C / Z+20°C	Z+105°C / Z+20°C
	0.75~1.25	0.75~1.25
Load life (after application of the rated voltage for 5000 hours at 105°C)	Leakage current	Less than specified value
	Capacitance change	Within ±20% of initial value
	ESR	Less than 200% of specified value
	tanδ	Less than 200% of specified value
Resistance to soldering heat (Refer to page 25 for soldering recommendation)	Leakage current	Less than specified value
	Capacitance change	Within ±10% of initial value
	tanδ	Less than 130% of specified value

* In case of some problems for measured values, measure after applying rated voltage for 4 to 20V products or 20V derating voltage for 25V products for 120 minutes at 105°C.

DRAWING

Unit : mm

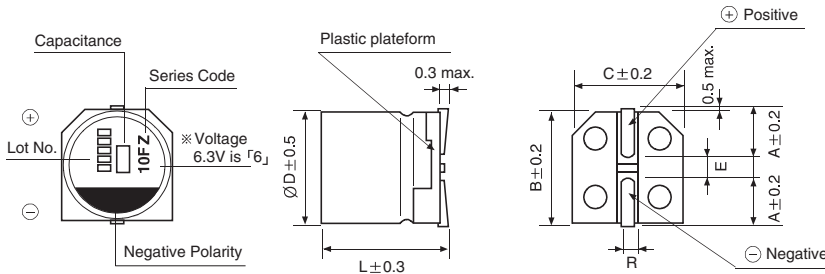

PART NUMBER SYSTEM (See Page 46)

Size	ØD	L	B	C	E	A	R
4×5.4	4	5.4	4.3	4.3	1	1.9	0.5-0.8
5×5.9	5	5.9	5.3	5.3	1.4	2.2	0.5-0.8
6.3×5.9	6.3	5.9	6.6	6.6	2.2	2.45	0.5-0.8
8×6.9	8	6.9	8.3	8.3	3.0	2.9	0.5-0.8
10×7.9	10	7.9	10.3	10.3	4.6	3.2	0.8-1.1

DIMENSIONS

µF	WV(SV)	4(5.2)	6.3(8.2)	10(11.5)	16(18.4)	20(23)	25(25)
10				4×5.4			8×6.9
15				4×5.4			
22			4×5.4		5×5.9	6.3×5.9	
33		4×5.4		5×5.9			
39					6.3×5.9		
47			5×5.9			8×6.9	
68		5×5.9		6.3×5.9			
82					8×6.9		
100					10×7.9		
120			6.3×5.9				
150		6.3×5.9		8×6.9			
150				10×7.9			
180					10×7.9		
220			8×6.9				
270		8×6.9					
330				10×7.9			
470			10×7.9				
680		10×7.9					

Case size ØD×L(mm)

SOLID TYPES

CONDUCTIVE POLYMER ALUMINUM ELECTROLYTIC CAPACITORS

FZ Series

● Table 1. FZ(SMD type) Series Characteristics List

WV	μ F	ØD(mm)	L(mm)	ESR(m Ω)max. 100~300kHz	Ripple current (mA rms)at 105°C 100kHz	Dissipation factor 120Hz	Leakage Current (μ A)(max.) after 2 minutes
4	33	4	5.4	200	740	0.15	66
4	68	5	5.9	30	1970	0.12	300
4	150	6.3	5.9	22	2570	0.12	300
4	270	8	6.9	22	3220	0.12	500
4	680	10	7.9	20	4130	0.12	544
6.3	22	4	5.4	200	740	0.12	69.3
6.3	47	5	5.9	30	1970	0.12	300
6.3	120	6.3	5.9	22	2570	0.12	300
6.3	220	8	6.9	22	3220	0.12	500
6.3	470	10	7.9	20	4130	0.12	592
10	10	4	5.4	220	700	0.1	50
10	15	4	5.4	200	740	0.1	75
10	33	5	5.9	70	1100	0.12	165
10	68	6.3	5.9	30	2200	0.12	300
10	150	8	6.9	30	2760	0.12	500
10	150	10	7.9	30	3020	0.12	300
10	330	10	7.9	24	3770	0.12	660
16	22	5	5.9	90	1060	0.1	176
16	39	6.3	5.9	24	2460	0.12	300
16	82	8	6.9	30	2760	0.12	262
16	100	10	7.9	35	2670	0.12	320
16	180	10	7.9	29	3430	0.12	576
20	22	6.3	5.9	60	1450	0.1	88
20	47	8	6.9	45	1890	0.12	188
25	10	8	6.9	60	1500	0.1	125

FN Chip type, Height 4.5mmL Series

- Low ESR, high ripple current
- Designed for surface mounting on Notebook PC
- Complied to the RoHS directive

Hi-CAP



Item	Characteristics	
Operating temperature range	-55 ~ +105°C	
Leakage current max.*	Less than or equal to the value of Table 1	
Capacitance tolerance	±20% at 120Hz, 20°C	
Dissipation factor max.	Less than or equal to the value of Table 1	
ESR	Less than or equal to the value of Table 1	
Temperature characteristics (Impedance ratio at 100kHz)	Z-55°C / Z+20°C	Z+105°C / Z+20°C
	0.75~1.25	0.75~1.25
Load life (after application of the rated voltage for 1000 hours at 105°C. In case 25WV is applied 20V)	Leakage current	Less than specified value
	Capacitance change	Within ±20% of initial value
	ESR	Less than 150% of specified value
	tanδ	Less than 150% of specified value
Resistance to soldering heat (Refer to Page 25 for soldering recommendation)	Leakage current	Less than specified value
	Capacitance change	Within ±10% of initial value
	tanδ	Less than 130% of specified value

* In case of some problems for measured values, measure after applying rated voltage for 120 minutes at 105°C.

DRAWING

Unit : mm

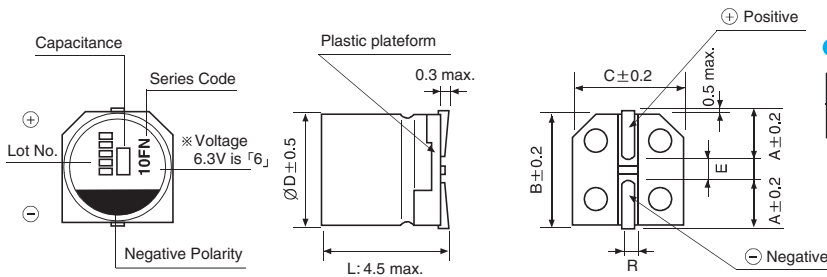

PART NUMBER SYSTEM (See Page 46)

Size	ØD	L	B	C	E	A	R
6.3×4.5	6.3	4.5	6.6	6.6	2.2	2.45	0.5~0.8

DIMENSIONS

µF \ WV(SV)	2.5 (3.3)	4 (5.2)	6.3 (8.2)	10 (11.5)	16 (18.4)	20 (23)	25 (25)
15						6.3 × 4.5	6.3 × 4.5
22					6.3 × 4.5		
47				6.3 × 4.5			
100			6.3 × 4.5				
120		6.3 × 4.5					
150	6.3 × 4.5						

Table 1. FN(Chip type) Series Characteristics List

WV	µF	ØD (mm)	L(mm)	ESR(mΩ)max. 100~300kHz	Ripple current (mA rms) at 105°C 100kHz	Dissipation factor 120Hz	Leakage Current (µA)(max.) after 2 minutes
2.5	150	6.3	4.5	38	1710	0.12	188
4	120	6.3	4.5	38	1710	0.12	240
6.3	100	6.3	4.5	40	1670	0.12	315
10	47	6.3	4.5	41	1560	0.12	235
16	22	6.3	4.5	45	1490	0.12	176
20	15	6.3	4.5	55	1650	0.12	150
25	15	6.3	4.5	55	1650	0.12	188

CONDUCTIVE POLYMER ALUMINUM ELECTROLYTIC CAPACITORS

FJ Lead type, With Conductive Polymer Series

- Low ESR, high ripple current
- Load life for 2000 hours at 105°C
- Complied to the RoHS directive

Hi-CAP

FB → FJ
Low ESR
High Cap.

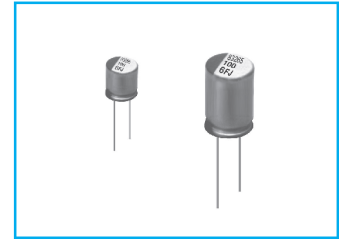

Item	Characteristics	
Operating temperature range	-55 ~ +105°C	
Leakage current max.*	Less than or equal to the value of Table1	
Capacitance tolerance	±20% at 120Hz, 20°C	
Dissipation factor max.	Less than or equal to the value of Table1	
ESR	Less than or equal to the value of Table1	
Temperature characteristics (Impedance ratio at 100kHz)	Z-55°C / Z+20°C	Z+105°C / Z+20°C
	0.75~1.25	0.75~1.25
Load life (after application of the rated voltage for 2000 hours at 105°C)	Leakage current	Less than specified value
	Capacitance change	Within ±20% of initial value
	ESR	Less than 150% of specified value
	tanδ	Less than 150% of specified value

* In case of some problems for measured values, measure after applying rated voltage for 120 minutes at 105°C.

DRAWING

Unit : mm

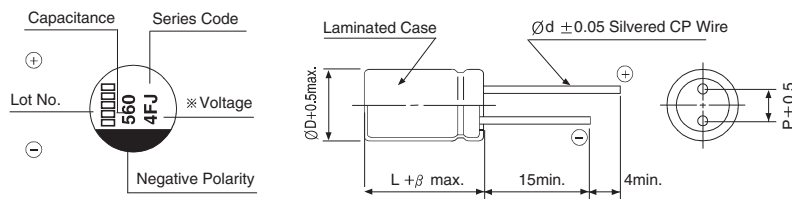

PART NUMBER SYSTEM (See Page 74)

Size	ØD	L	P	Ød	β
6.3×8	6.3	8.0	2.5	0.45	0.5
8×9	8	9.0	3.5	0.6	0.5
8×12	8	12.0	3.5	0.6	0.5
10×13	10	13.0	5.0	0.6	0.5

DIMENSIONS

µF	WV(SV)	2.5(3.3)	4(5.2)	6.3(8.2)	16(18.4)
100					6.3 × 8
180					8 × 12
270					8 × 12
330		6.3 × 8			
470				8 × 9	
				8 × 12	10 × 13
560		6.3 × 8	6.3 × 8		
		8 × 9	8 × 9	8 × 9	
			8 × 12		
680			8 × 12	10 × 13	
820		6.3 × 8			
		8 × 9			
		8 × 12	10 × 13		
1000		8 × 12			
1500				10 × 13	
2700		10 × 13			

← Case size ØD×L(mm)

FJ Series

● Table 1. FJ(Lead type) Series Characteristics List

WV	μF	∅D(mm)	L(mm)	ESR(mΩ)max. 100~300kHz	Ripple current (mA rms)at 105°C 100kHz	Dissipation factor 120Hz	Leakage Current (μA)(max.) after 2 minutes
2.5	330	6.3	8	7	5600	0.10	500
2.5	560	6.3	8	7	5600	0.10	500
2.5	560	8	9	8	4700	0.10	280
2.5	820	6.3	8	7	5600	0.10	513
2.5	820	8	9	5	7200	0.10	500
2.5	1000	8	9	7	6100	0.10	500
2.5	820	8	12	5	7200	0.10	500
2.5	2700	10	13	10	5560	0.10	1350
4	560	6.3	8	7	5600	0.10	560
4	560	8	9	5	7200	0.10	500
4	560	8	12	5	7200	0.10	500
4	680	8	12	5	7200	0.10	544
4	820	10	13	7	6640	0.10	656
6.3	470	8	9	8	5700	0.10	592
6.3	470	8	12	8	5700	0.10	592
6.3	560	8	9	7	6100	0.10	706
6.3	680	10	13	7	6640	0.10	857
6.3	1500	10	13	10	5560	0.10	1890
16	100	6.3	8	10	4680	0.10	500
16	180	8	12	16	4360	0.10	576
16	270	8	12	11	5000	0.10	864
16	470	10	13	10	6100	0.10	1504

SOLID TYPES

CONDUCTIVE POLYMER ALUMINUM ELECTROLYTIC CAPACITORS

FB Lead type, With Conductive Polymer Series

Hi-CAP

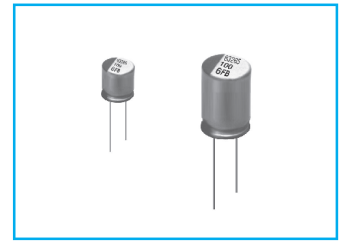

- Low ESR, high ripple current
- Load life for 2000 hours at 105°C
- Complied to the RoHS directive

FB \rightleftarrows **FJ**
Low ESR
High Cap.

Item	Characteristics	
Operating temperature range	-55 ~ +105°C	
Leakage current max.*	Less than or equal to the value of Table1	
Capacitance tolerance	±20% at 120Hz, 20°C	
Dissipation factor max.	Less than or equal to the value of Table1	
ESR	Less than or equal to the value of Table1	
Temperature characteristics (Impedance ratio at 100kHz)	Z-55°C / Z+20°C	Z+105°C / Z+20°C
	0.75~1.25	0.75~1.25
Load life (after application of the rated voltage for 2000 hours at 105°C, In case of 25WV is applied 20V)	Leakage current	Less than specified value
	Capacitance change	Within ±20% of initial value
	tanδ	Less than 150% of specified value

* In case of some problems for measured values, measure the after applying rated voltage for 2.5 to 20V products or 20V derating voltage for 25V products for 120 minutes at 105°C.

● DRAWING

Unit : mm

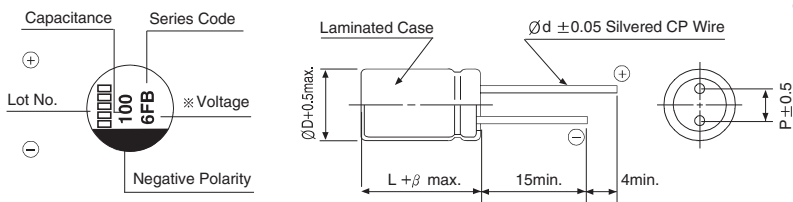

● PART NUMBER SYSTEM (See Page 74)

Size	∅D	L	P	∅d	β
6.3×6	6.3	6.0	2.5	0.45	0.5
6.3×8	6.3	8.0	2.5	0.45	0.5
8×9	8	9.0	3.5	0.6	0.5
8×12	8	12.0	3.5	0.6	0.5
10×13	10	13.0	5.0	0.6	0.5

● DIMENSIONS

μF \ WV(SV)	2.5(3.3)	4(5.2)	6.3(8.2)	10(11.5)	16(18.4)	20(23)	25(25)
6.8							6.3×6
10							6.3×8
18							6.3×8
22						6.3×6	8×12
33							8×12
39					6.3×6		
47				6.3×6		6.3×8	
56				6.3×6		6.3×8	8×12
68				6.3×6		6.3×8	8×12
82			6.3×6		6.3×8		
100		6.3×6		6.3×8	6.3×8	8×12	8×12
120				6.3×8			
150		6.3×6	6.3×8	6.3×8		10×13	
180					8×12		
220		6.3×8	6.3×8				
270		6.3×8		8×12	8×12		
330		6.3×8	8×9	8×12	10×13		
390	6.3×8	6.3×8		8×12			
470		8×9	8×9	8×12	10×13		
560	8×9	8×9		10×13			
680	8×9	8×9	8×9	10×13			
820	8×9		8×12				
1000	8×9		8×12				
1200		8×12	10×13				
1500	8×12		10×13				
2700	10×13						
3300	10×13						

← Case size ∅D×L(mm)

FB Series

● Table 1. FB(Lead type) Series Characteristics List

WV	μF	ØD(mm)	L(mm)	ESR(mΩ)max. 100~300kHz	Ripple current (mA rms)at 105°C 100kHz	Dissipation factor 120Hz	Leakage Current (μA)(max.) after 2 minutes
2.5	390	6.3	8	20	3160	0.10	195
2.5	560	8	9	7	6100	0.10	280
2.5	680	8	9	7	6100	0.10	340
2.5	820	8	9	7	6100	0.10	410
2.5	1000	8	9	7	6100	0.10	500
2.5	1500	8	12	8	5500	0.10	750
2.5	2700	10	13	8	5560	0.10	1350
2.5	3300	10	13	8	6650	0.10	1650
4	100	6.3	6	40	1810	0.10	80
4	150	6.3	6	40	1810	0.10	120
4	220	6.3	8	35	2560	0.10	176
4	270	6.3	8	20	3160	0.10	216
4	330	6.3	8	24	3300	0.10	264
4	390	6.3	8	24	3300	0.10	312
4	470	8	9	8	5700	0.10	376
4	560	8	9	7	6100	0.10	448
4	680	8	9	7	6100	0.10	544
4	1200	8	12	8	5700	0.10	960
6.3	82	6.3	6	45	1700	0.10	103
6.3	150	6.3	8	35	2560	0.10	189
6.3	220	6.3	8	20	3160	0.10	277
6.3	330	8	9	28	3190	0.10	416
6.3	470	8	9	8	5700	0.10	592
6.3	680	8	9	7	6640	0.10	857
6.3	820	8	12	7	6640	0.10	1033
6.3	1000	8	12	8	6100	0.10	1260
6.3	1200	10	13	10	5560	0.10	1520
6.3	1500	10	13	10	5560	0.10	1890
10	47	6.3	6	25	2820	0.10	94
10	56	6.3	6	25	2820	0.10	112
10	68	6.3	6	25	2820	0.10	136
10	100	6.3	8	25	2820	0.10	200
10	120	6.3	8	35	2560	0.10	240
10	150	6.3	8	25	2820	0.10	300
10	270	8	12	9	4710	0.10	540
10	330	8	12	9	4710	0.10	660
10	390	8	12	9	5650	0.10	780
10	470	8	12	8	5650	0.10	940
10	560	10	13	8	5650	0.10	1120
10	680	10	13	7	6100	0.10	1360
16	39	6.3	6	50	1620	0.10	124
16	82	6.3	8	25	2120	0.10	262
16	100	6.3	8	25	2820	0.10	320
16	180	8	12	16	4360	0.10	576
16	270	8	12	11	5000	0.10	864
16	330	10	13	10	6100	0.10	1056
16	470	10	13	10	6100	0.10	1504
20	22	6.3	6	60	1450	0.12	88
20	47	6.3	8	25	2820	0.12	188
20	56	6.3	8	25	2820	0.12	224
20	68	6.3	8	25	2820	0.12	272
20	100	8	12	24	3320	0.12	400
20	150	10	13	20	4320	0.12	600
25	6.8	6.3	6	80	1200	0.12	85
25	10	6.3	8	60	1500	0.12	125
25	18	6.3	8	40	2230	0.12	225
25	22	8	12	40	2230	0.12	275
25	33	8	12	30	2980	0.12	413
25	56	8	12	30	3800	0.12	700
25	68	8	12	25	3320	0.12	850
25	100	8	12	20	4320	0.12	1250

SOLID TYPES

CONDUCTIVE POLYMER ALUMINUM ELECTROLYTIC CAPACITORS

FC Chip type, With Conductive Polymer Series

Hi-CAP

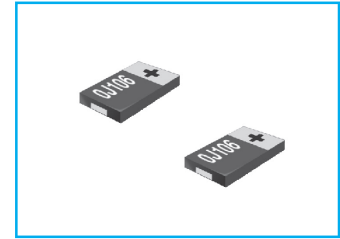

- Low ESR, high ripple current
- Excellent noise-absorbent characteristics
- Very stable capacitance, impedance and ESR against temperature
- Designed for use smoothing circuit of power supplies and noise limiter
- Complied to the RoHS directive

Item	Characteristics				
Operating temperature range	-40 ~ +105°C				
Leakage current max.	I = 0.04CV or 3μA whichever is greater (after 2 minutes)				
Capacitance tolerance	±20% at 120Hz, 20°C				
Dissipation factor max.	0.06 max. at 120Hz, 20°C				
ESR	ESR at 20°C 100kHz, as per table below				
Load life (after application of the rated voltage for 1000 hours at 105°C)	Leakage current	Less than specified value			
	Capacitance change	Within ±20% of initial value			
	tanδ	Less than 150% of specified value			
Moisture resistance (after leaving capacitors under no load at 60°C for 500 hours 90% R.H.)	Leakage current	Less than 300% of specified value			
	Capacitance change of Initial value	2, 2.5V.DC	4V.DC	6.3V.DC	8-16V.DC
		+70, -20%	+60, -20%	+50, -20%	+40, -20%
	tanδ	Less than 150% of specified value			

● DRAWING

Unit : mm

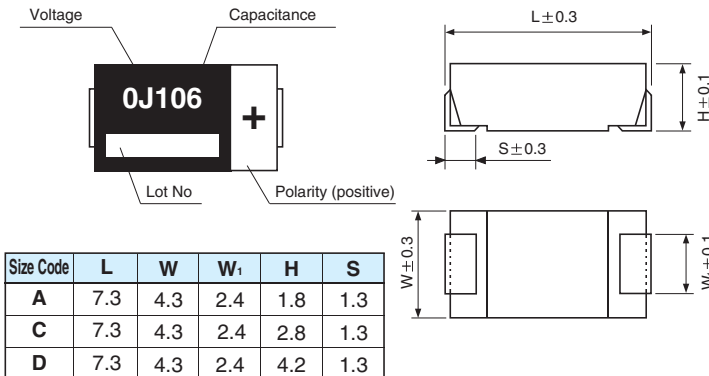

● PART NUMBER SYSTEM (See page 46) (Example : 6.3V 10μF)

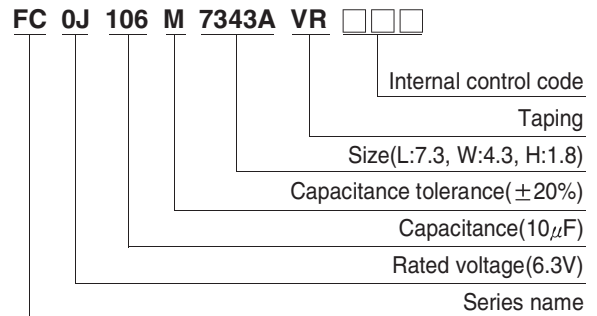

● DIMENSIONS & MAXIMUM PERMISSIBLE RIPPLE CURRENT

μF	2			2.5			4			6.3			8			12.5			16			
	WV																					
2.2																						
4.7																	80	1000	A	80	1000	A
6.8																			70	1000	A	
8.2																			45	1300	A	
10										55	1400	A				60	1000	A				
15								55	1400	A				40	1600	A	50	1300	A			
22					55	1400	A			40	1600	A	28	2000	A	30	1600	A				
33	55	1400	A					40	1600	A	28	2000	A	18	2500	A						
47				40	1600	A	28	2000	A	18	2500	A										
56	40	1600	A																			
68				28	2000	A	18	2500	A													
82	28	2000	A	18	2500	A																
100	18	2500	A							10	3500	C	18	2500	D							
120																						
150								10	3500	C	10	3500	D	15	3000	D						
180								7	3700	D	7	3700	D									
220	10	3500	C	10	3500	C	7	3700	D													
330	10	3500	C	7	3700	D																
390	7	3700	D	7	3700	D																
470	7	3700	D																			

Size code
Ripple current (mA rms) at 105°C, 100kHz
ESR (mΩ) max. at 20°C, 100kHz